



POCONO TOWNSHIP COMMISSIONERS
AGENDA

April 16, 2018 6:45 p.m.
St. Luke's Ambulance Building

Open Meeting

Pledge of Allegiance

Roll Call

Public Comments

Comments are for any issue. Please limit individual comments to 5 minutes to allow time for others wishing to speak and direct all questions and comments to the President.

Interview –

James Moloughney – Alternate Civil Service Board – (possible action item*)

Announcements –

Hearings –

Presentations –

Airpark Resort (formerly Spa Castle) – brief presentation concerning mandatory sewer requirements **(NOT an action item)**

OLD BUSINESS

1. Approve minutes of the April 2, 2018 Meeting of Board of Commissioners (action item*)

NEW BUSINESS

1. Personnel

- a. Motion to rehire Catherine Needle as seasonal park employee at \$13.00/hour, not to exceed 32 hours per week, effective April 21, 2018.
- b. Motion to offer conditional offer of employment to the following three police officer candidates, as recommended by the Civil Service Commission and pending outcome of additional testing –
 - Ryan Melley
 - James Scott
 - Joseph Bianchi

(Action Item*)

*A matter listed as an "Action Item" on the Agenda is a matter that the Board of Commissioners will discuss and may deliberate or take official action on. A matter listed on the Agenda as an "Action Item" does not require the Board of Commissioners to deliberate or take official action on that matter.

** Change to agenda versus draft posted on website

- c. Motion to approve Phillip Starner Leave of Absence through May 29, 2018, with mandatory use of benefit time (action item*)
2. Financial Transactions
 - a. Ratify vouchers payable for the period ending April 13, 2018 in the amount of \$ 579.72 (action item*)
 - b. Ratify gross payroll for pay period ending April 8, 2018 in the amount of \$ 100,972.00 (action item*)
 - c. **Approve vouchers payable received through April 13, 2018 in the amount of \$ 364,745.97 (action item*)
 - d. Motion to submit invoices for reimbursement through LSA grant in the amount of \$109,214.00 (action item*)
 3. Travel/Training Authorizations (Approve/Ratify)
 - a. Motion to approve Commissioner Belvin attending the PSATC Annual Conference June 21 – 24th at Skytop Lodge including registration and day attendance costs of approximately \$200.00 (action item*)

Report of the President

- a. Library space

Commissioners Comments

Bob De Young – Vice President

Harold Werkheiser – Commissioner

Rich Wielebinski – Commissioner

- Dangerous Structure – 2765 Route 611
- Dangerous Structures –
 - Lot 2 – Sullivan Trail
 - 2812 Bartonsville Avenue

Jerrold Belvin – Commissioner

- Motion for the Solicitor to prepare Amusement Tax Ordinance (action item*)
- Motion to have IUP Conduct a Safety Study on township buildings, PD, PW & Admin (action item*)

Reports

- a. Emergency Service
 - i. Police
 - ii. EMS
 - iii. Fire
- b. Park Board
- c. Finance Committee
- d. Sewer Committee
 - Kalahari – received check for 2017 overages
 - BCRA Rerate

(Action Item*)

*A matter listed as an “Action Item” on the Agenda is a matter that the Board of Commissioners will discuss and may deliberate or take official action on. A matter listed on the Agenda as an “Action Item” does not require the Board of Commissioners to deliberate or take official action on that matter.

** Change to agenda versus draft posted on website

Administration – Manager's Report

- i. Report on school bus stop sign as per motion on March 22nd
 - ii. Correspondence from Monroe County Tax Collection Committee, opposing House Resolution No 291 to replace collection of local earned income tax by local company with the Department of Revenue
 - iii. Motion to consider letter of support for NCC submittal of grant proposal for walking trail around campus (possible action item*)
 - iv. Motion to award sale of 2011 Ford Crown Victoria to Peter Bajuz in the amount of \$1,325.00 as highest bidder on municibid (action item*)
 - v. Motion to award sale of 2013 Ford Police Interceptor to Michael Bearer in the amount of \$4,756.00 as highest bidder on municibid (action item*)
 - vi. Motion to authorize manager to send letter to DEP confirming that Cameltop Lodge is in the Camelback WWTP service area (action item*)
- e. Public Works Report
- i. Motion to award purchase of Single Axle Truck to Peterbilt for \$93,991.00 as per co-star quote. (action item*)
 - ii. Motion to award purchase of Single Axle Truck Body to E.M. Kutz for \$64,661.00 as per co-star quote (action item*)
 - iii. Motion to award purchase of Tandem Truck to Peterbilt for \$127,706.00 as per co-star quote (action item*)
 - iv. Motion to award purchase of Tandem Truck Body to E.M. Kutz for \$70,489.00 as per co-star quote (action item*)
- f. Township Engineer Report
- i. Update Status Report on Sewer Redesign
 - ii. Update on Route 611 Sewer Line Relocation Work Update
 - iii. Update on Sanofi Sanitary Sewer Easement
 - iv. Update on enclosure for Valve Station #5
 - v. Update on White Oak Culvert replacement project
 - vi. Update on Fish Hill Road Storm System Notice of violation from MCCD (possible action item*)
 - vii. Motion to approve Payment Application No. 7 to The Milnes Company, in the amount of \$34,910.55 as recommended by Boucher & James. (action item*)
- g. Township Solicitor Report
- i. Update on Exxon Monitoring Wells Agreement
 - ii. Motion to schedule hearing date for Ordinance on codification of township ordinances for May 15, 2018 (action item*)
 - iii. Motion to approve settlement with Fontaine vs Pocono Township (action item*)

Resolutions

Public Comment

Please limit individual comments to 5 minutes to allow time for others wishing to speak and direct all questions and comments to the President.

Executive Session – if necessary

Adjournment

(Action Item*)

*A matter listed as an "Action Item" on the Agenda is a matter that the Board of Commissioners will discuss and may deliberate or take official action on. A matter listed on the Agenda as an "Action Item" does not require the Board of Commissioners to deliberate or take official action on that matter.

** Change to agenda versus draft posted on website

POCONO TOWNSHIP BOARD OF COMMISSIONERS

REGULAR MEETING MINUTES

APRIL 2nd, 2018 7:00 P.M.

DRAFT

The Regular meeting of the Pocono Township Commissioners was held on Monday April 2, 2018 at the Pocono Township Municipal Building, Tannersville, PA, and was opened by President Gerald Lastowski at 7:00 p.m., followed by the Pledge of Allegiance.

ROLL CALL: Gerald Lastowski, present; Bob M. DeYoung, absent; Harold Werkheiser, absent; Richard Wielebinski, present; and Jerrod Belvin, present.

IN ATTENDANCE:

Leo DeVito, Twp. Solicitor, Broughal & DeVito; Jon Tresslar, Twp. Engineer, Boucher & James, Inc.; DonnaASURE, Township Manager; and Pamela Tripus, Township Secretary, were present.

PUBLIC COMMENT:

Joe Folsom, Twp. resident, questioned the status of the interrupters. J. Tresslar, Twp. Engineer, will investigate and report back to the Board. Linda Hillard, Twp. resident, spoke in favor of the Pocono Township Library.

Ellen Gndt, Twp. resident, questioned the ratification of the engagement letter for the auditors. D.ASURE, Twp. Manager, explained Zelenkofske Axelrod, LLC required a separate engagement letter for compilation of information for a timely filing to DCED. E. Gndt asked if the filing can be posted to the website. D.ASURE will confirm with the Auditor.

Ellen Gndt, Twp. resident, questioned the agenda items that were not listed on the previous agenda.

Ellen Gndt, Twp. resident, questioned the minutes with a motion for concerning advertising.

Ellen Gndt, Twp. resident, commented on the by-laws concerning changes the agenda.

ANNOUNCEMENTS:

Executive Session was held on March 22nd, 2018 for personnel matters.

Executive Session was held on April 2nd, 2018 for personnel matters.

Airpark Resort (formerly Spa Castle) will present/discuss sewer needs at the Regular Board of Commissioners Meeting scheduled for April 16th, 2018 at 7:00 p.m. The meeting will be held at the St. Luke's Ambulance Bldg.

MINUTES:

R. Wielebinski made a motion, seconded by J. Belvin, to approve the Board of Commissioners 03/19/2018 Work Session Minutes.

Roll call: R. Wielebinski, yes; J. Lastowski, yes; and J. Belvin, yes.

Motion carried.

J. Belvin, made a motion, seconded by J. Lastowski, to approve the Board of Commissioners 03/19/2018 Regular meeting minutes. Roll call: R. Wielebinski, yes; J. Lastowski, yes; and J. Belvin, yes. Motion carried.

DRAFT

R. Wielebinski made a motion, seconded by J. Belvin, to approve the Board of Commissioners Special Meeting Minutes of 03/22/2018. Roll call: R. Wielebinski, yes; J. Lastowski, yes; and J. Belvin, yes. Motion carried.

PERSONNEL:

R. Wielebinski made a motion, seconded by J. Belvin, to hire Kevin Daher as seasonal Lead Park employee for Pocono Township Parks at a rate of \$16.00 per hour, for not more than 39 hours per week, effective Wednesday, April 4th, 2018. R. Wielebinski explained the lead position is required so they will be able to schedule park employees without violating the present CBA. Roll call: R. Wielebinski, yes; J. Lastowski, yes; and J. Belvin, yes. Motion carried.

J. Lastowski made a motion, seconded by R. Wielebinski, to hire James Boyle as seasonal park employee for Pocono Township Parks at a rate of \$14.50 per hour, for not more than 32 hours per week, effective Wednesday, April 4th, 2018. Roll call: R. Wielebinski, yes; J. Lastowski, yes; and J. Belvin, yes. Motion carried.

J. Lastowski made a motion, seconded by R. Wielebinski, to rehire Jack Manuel as seasonal Public Works employee for Pocono Township Parks at a rate of \$14.89 per hour. Roll call: R. Wielebinski, yes; J. Lastowski, yes; and J. Belvin, yes. Motion carried.

FINANCIAL TRANSACTIONS:

J. Belvin made a motion, seconded by J. Lastowski, to ratify vouchers payable for the period ending 03/29/2018 in the amount of \$2,497.52. Roll call: R. Wielebinski, yes; J. Lastowski, yes; and J. Belvin, yes. Motion carried.

R. Wielebinski made a motion, seconded by J. Lastowski, to ratify gross payroll totaling \$79,564.88 for pay period ending 03/25/2018. Roll call: R. Wielebinski, yes; J. Lastowski, yes; and J. Belvin, yes. Motion carried.

R. Wielebinski made a motion, seconded by J. Lastowski, to approve vouchers payable totaling \$160,399.37 for period ending 03/29/2018. Roll call: R. Wielebinski, yes; J. Lastowski, yes; and J. Belvin, yes. Motion carried.

R. Wielebinski made a motion, seconded by J. Lastowski, to approve Capital purchases through March 29th, 2018 in the amount of \$16,425.00. Roll call: R. Wielebinski, yes; J. Lastowski, yes; and J. Belvin, yes. Motion carried.

DRAFT

REPORT OF THE PRESIDENT:

Gerald Lastowski, President

Sewer Committee Meetings - J. Lastowski explained due to the issues coming before the current sewer committee; he recommended the Sewer Committee include the whole Board as it was done in the past. J. Lastowski made a motion, seconded by R. Wielebinski, to have the whole Board of Commissioners on the Sewer Committee and to hold Sewer meetings at 6:00 p.m. prior to the 1st regular BOC meeting of each month. Roll call: R. Wielebinski, yes; J. Lastowski, yes; and J. Belvin, yes. Motion carried.

Discussion on space for Library - J. Lastowski recommended one or two Commissioners meet with the Library Board to investigate the possibility of a larger space for the Library. J. Lastowski noted his goal is to be fair to the taxpayers and the Library for the best solution for both. R. Wielebinski requested all Board of Commissioners be present to discuss the Library. J. Lastowski requested D.ASURE, Twp. Manager, put the Library Space on the next agenda.

COMMISSIONERS COMMENTS:

Robert M. DeYoung, Vice-President - Absent.

Harold Werkheiser, Commissioner - Absent.

Richard Wielebinski, Commissioner -

Civil Service Commission Alternates - R. Wielebinski explained there is an opening for an alternate for the Civil Service Commission and two applicants have applied. He recommended the candidates be interviewed before the next meeting. The Board concurred to interview before the 04/16/2018 meeting. D.ASURE will advertise the 04/16/2018 for 6:45p.m. for the interviews and change of location to St. Luke's Ambulance.

Jerrod Belvin, Commissioner -

COG Update - J. Belvin explained at the last COG meeting they discussed the lack of volunteers for the area Fire Departments. He noted the Township does not have an Act 172 which gives volunteer firemen a tax break. Discussion followed. J. Lastowski noted the fire company has been contacted.

911 Signs - J. Belvin noted approximately 50% of property owners did not post the 911 signs, as required, on their property. Discussion followed on steps necessary to bring properties in compliance. Joe Folsom, Pocono Township Fire Company, offered to provide the database from the original 911 addressing project.

Registration Update- J. Belvin noted the County is not pursuing the \$5.00 vehicle registration tax.

COMMISSIONER BELVIN CONT:

ID Status - J. Belvin noted photos of Twp. Employees have been submitted to the County for ID badges.

Pennsylvania Municipal Internship Program - J. Belvin explained the program is to allow college students to intern for 6 months to 1 year at the Township. J. Lastowski made a motion, seconded by J. Belvin, to enter into the Pennsylvania Internship program. Since it was not an agenda item, J. Lastowski opened the discussion for public comment. E. Gnanadt, twp. resident, questioned if it would interfere with the Union employees. Roll call: R. Wielebinski, yes; J. Lastowski, yes; and J. Belvin, yes. Motion carried.

REPORTS:

Sewer Committee -

Kalahari - J. Lastowski reported on a meeting with Kalahari, Tobyhanna, and BCRA representatives. He noted Kalahari is paying \$1,215,000.00 for the additional taping fees and will be providing a Letter of Credit for \$500,000 for three months to allow monitoring of usage. If Kalahari does not reduce their usage, the Line of Credit will be used for the purchase of additional EDUs. D. Asure noted Kalahari will submit a check in the amount of \$151,000 for overages. Tobyhanna is requesting additional use of the Township's sewer line for future growth. Discussion followed on the rerating of the BCRA plant. R. Wielebinski requested the whole board be present before a decision is made.

Administration - Manager's Report -

Lease-purchase of Copiers for Township and Police Buildings - D. Asure noted quotes were received from Topp Business Solutions and Access Office Technologies. J. Lastowski made a motion, seconded by J. Belvin, to approve entering into an agreement with Access Office Technologies for the lease-purchase of three copiers for Pocono Township Municipal building and Police Department for a total lease payment not to exceed \$16,221.00. Roll call: R. Wielebinski, yes; J. Lastowski, yes; and J. Belvin, yes. Motion carried.

Zelenkofske Axelrod, LLC - D. Asure noted the engagement letter is for the filing of the DCED report. J. Lastowski made a motion, seconded by R. Wielebinski, to ratify the engagement letter with Zelenkofske Axelrod, LLC to complete the mandatory DCED report due by April 1st, 2018. Roll call: R. Wielebinski, yes; J. Lastowski, yes; and J. Belvin, yes. Motion carried.

Site 2 Contract - D. Asure, Twp. Manager, explained additional quotes were received from Micro Technology Group, Inc., and IntergraONE. Discussion followed. J. Lastowski directed D. Asure, Twp. Manager, and L. DeVito, Twp. Solicitor, to address the issues and bring back a recommendation to the Board.

POCONO TOWNSHIP COMMISSIONERS' REGULAR MEETING, 04/02/2018
ADMINISTRATION REPORT CONT:

DRAFT
PG. 5

Codification Ordinance - D. Asure noted General Code has completed the codification of the Township Ordinances. Discussion followed on conflicting schedules for the May BOC meetings. The Board will confirm the dates for May BOC meetings.

J. Lastowski made a motion, seconded by J. Belvin, to authorize the Twp. Solicitor to advertise for a hearing on the 1st regular BOC meeting in May to adopt the Codification of Township Ordinances. Roll call: R. Wielebinski, yes; J. Lastowski, yes; and J. Belvin, yes. Motion carried.

Great American Clean-up

D. Asure announced The Great American Clean-up will be held from March 1st to May 31st, 2018. Residents may register with Monroe County Municipal Waste Management Authority by contacting Cindy Parks: cparks@thewasteauthority.com. R. Wielebinski requested it be placed on the billboards.

2018 PSATC Conference - D. Asure explained the 2018 Pennsylvania State Association of Township Commissioners (PSATS) conference will be held 06/21/2018 to 06/24/2018 at Skytop Lodge.

Eagle Scout Jared Thomas Cziko

D. Asure informed the board that an invitation was received requesting the Board of Commissioners attend the Eagle Scout Ceremony for Jared Thomas Cziko, 05/12/2018 at 1:00 p.m., at St. Luke's Hall. J. Lastowski noted a second Scout from Troup 85 is obtaining the rank of Eagle Scout. D. Asure will invite the Eagle Scout candidates to a future Board meeting.

Short Term Rentals

D. Asure, Twp. Manager, explained Michael Tripus, Zoning Officer, and herself held a conference call with Host Compliance a company that identifies Short Term Rental properties. Host Compliance believes there are 200 short term rentals in Pocono Township. Host Compliance does the leg work to find the addresses of short term rentals. M. Tripus, ZO, noted it takes hours to research each rental property. Discussion followed. L. DeVito, Twp. Solicitor requested time to review the contract and contact the references.

Public Works Report -

Road Paving Project - D. Asure, Twp. Manager, explained the Township received six bids. She explained the escalator clause will result in an increase in cost for last year's bid. Discussion followed on funding the additional cost.

J. Lastowski made a motion, seconded by J. Belvin, to award the Road Paving Bid for approximately 2.3 miles of additional roads to Hanson Aggregates, LLC as the lowest responsible bidder in the amount of \$295,500.00. Roll call: R. Wielebinski, yes; J. Lastowski, yes; and J. Belvin, yes. Motion carried.

J. Lastowski requested D. Asure to submit a list of all road projects to the Board.

J. Lastowski thanked D. Asure for all of her work.

TOWNSHIP ENGINEER REPORT:

Status Report on Sewer Redesign - J. Tresslar, Twp. Engineer, reported Valve Station #1 is fully functional and will be automated to Valve Station #2 once repairs to #2 is made. Keystone has been reviewing the wiring at the Pump Station and will be making recommendations to bring the Pump Stations up to code.

Route 611 Sewer Line Relocation Work Update - J. Tresslar, Twp. Engineer, noted a meeting is scheduled Wednesday with PennDOT and the contractors to get a schedule of work for the spring.

Sanofi Sanitary Sewer Easement - No report - waiting on PennDOT.

Enclosure for Valve Station #5 - J. Tresslar, Twp. Engineer, expects the bid to be out this week.

White Oak Culvert replacement project - J. Tresslar, Twp. Engineer, will provide plans to Robert Sargent, Road Supervisor, to review. He expects to submit the permit application to DEP, soon. Discussion followed on opening a Twp. road section during construction. J. Tresslar will work with L. DeVito, Twp. Solicitor, for the opening of the road to detour residents affected during the construction of the White Oak Culvert. He expected the work to be completed within two days. J. Lastowski requested all property owners effected to be notified.

Fish Hill Road Storm System Notice of Violation from MCCD - J. Tresslar, Twp. Engineer, inspected the area and found approximately 50' has eroded out along Fish Hill Road. R. Wielebinski questioned the culvert under the St. Paul's Church entrance. J. Tresslar noted several culverts are clogged with antiskid material along the road. Discussion followed on ownership the culverts and repairs required. J. Tresslar explained the project will be required to be reviewed by MCCD.

MCTA Road Dedication - J. Tresslar provided a letter concerning the dedication of MCTA Road. R. Wielebinski questioned the condition of the road surface of MCTA Road noting cracking on the road, and the opening of Flute Drive. J. Tresslar noted the Planning Commission discussed Flute Drive but did not make a recommendation. Discussion followed on the possible resident concerns that commercial vehicles would use Flute road through a residential neighborhood.

Valves for Pump Station 2 - J. Tresslar noted the valves required replacement. D. Asure noted Patrick Briegel reached out to Control Clay Products, Inc. and was able to obtain the valves for 500 less. J. Lastowski made a motion, seconded by J. Belvin, to ratify the purchase of two plug valves from Control Clay Products, Inc. for Valve Station 2 at a cost of \$2,029.50 each as recommended in Boucher & James Letter dated 03/19/2018 and by Patrick Briegel. Roll call: R. Wielebinski, yes; J. Lastowski, yes; and J. Belvin, yes. Motion carried.

PG. 7
DRAFT

TOWNSHIP SOLICITOR REPORT:

Update on Exxon Monitoring Well Agreement - L. DeVito, Twp. Solicitor, explained he sent a proposed draft agreement but has not received a response from Mr. Lopresti concerning the agreement to drill a monitoring well next to the Township's sewer line.

PUBLIC COMMENT:

Maxine Turbolski, Twp. resident, questioned the plans for the library. J. Lastowski noted they have not met with the Library and no decision has been made.

Maxine Turbolski, Twp. resident, questioned the 911 signs. J. Lastowski explained they are the green house number signs required by 911.

Maxine Turbolski, Twp. resident, requested the Board use the microphones. Ellen Gndt, Twp. resident, commented on the Host Compliance Service and the approval of the minutes without her suggested correction.

Ellen Gndt, Twp. resident, questioned if the position of the alternate on the Civil Service is opened to the public. R. Wielebinski explained it was advertised and two applicants applied.

Ellen Gndt, Twp. resident, commented on use of the Kalahari money and if road paving was in the budget. L. DeVito, Twp. Solicitor, noted it is being handled the same way as the previous board. D. Asure noted there is money in the Capital budget that will be used.

Ellen Gndt, Twp. resident, questioned if the audit will be published. J. Lastowski explained they will follow the legal requirements.

ADJOURNMENT:

R. Wielebinski made a motion, seconded by J. Belvin, to adjourn the meeting at 8:25 p.m. The next regularly scheduled meeting will be held on April 16th, 2018 at 6:45 p.m. at the St. Luke's Ambulance Building, Tannersville, PA. Roll call: R. Wielebinski, yes; J. Lastowski, yes; and J. Belvin, yes. Motion carried.

**POCONO TOWNSHIP
SEWER PROJECT INVOICES TO BE APPROVED
Monday, April 16, 2018**

| <u>Date</u> | <u>Check</u> | <u>Vendor</u> | <u>Memo</u> | <u>Amount</u> |
|---|--------------|----------------|--|-------------------------|
| 04/13/2018 | 254 | The Milnes Co. | Payment application 7 Project 1631006C | \$ 34,910.55 |
| TOTAL Sewer Construction Fund \$ | | | | <u>34,910.55</u> |

ESSA Transfer \$ 34,910.55 Transferred by: _____

Authorized by: _____

POCONO TOWNSHIP
Monday, April 16, 2018

SUMMARY

Ratify

| | | |
|--------------------|----|------------|
| General Fund | \$ | 101,251.97 |
| Sewer Operating | \$ | 299.75 |
| Sewer Construction | \$ | - |
| Capital Reserve | \$ | - |

Bill List

| | | |
|--------------------------------------|----|------------|
| TOTAL General Fund | \$ | 263,040.03 |
| TOTAL Sewer <u>OPERATING</u> Fund | \$ | 101,705.94 |
| TOTAL Sewer <u>CONSTRUCTION</u> Fund | \$ | - |
| TOTAL Capital Reserve Fund | \$ | - |

Budget Adjustments

| | |
|----|---|
| \$ | - |
|----|---|

Budget Appropriations

| | |
|----|---|
| \$ | - |
|----|---|

Notes:

Check # 2119 for \$ 2,919.14 was voided due to incorrect ammount. Check # 2123 for \$1,575 has replaced it. The difference of \$ 1,344.14 will be deducted from the sewer operating transfer.

POCONO TOWNSHIP CHECK LISTING
RATIFY
Monday, April 16, 2018

| General Fund | Date | Check | Vendor | Memo | Amount |
|--------------------------------------|------------|-------|-------------|------------------------------------|---------------------|
| Payroll | 04/03/2018 | | | VOGT PAYOUT | 18,331.73 |
| | 04/12/2018 | | | PAY 7 | 82,640.27 |
| TOTAL PAYROLL | | | | | \$100,972.00 |
| General Expenditures | 04/04/2018 | 56943 | FSOEP | Detective Training 4/18/18 | 25.00 |
| | 04/04/2018 | 56944 | PENTELEDATA | Internet Service | 254.97 |
| TOTAL General Fund Bills | | | | | \$ 279.97 |
| Sewer Operating Fund | 04/04/2018 | 2124 | PENTELEDATA | Internet connection sewer stations | 299.75 |
| TOTAL Sewer Operating Fund | | | | | \$ 299.75 |
| Sewer Construction Fund | | | | | - |
| TOTAL Sewer Construction Fund | | | | | \$ - |
| Capital Reserve Fund | | | | | - |
| TOTAL Capital Reserve Fund | | | | | \$ - |
| TOTAL General Fund | | | | | \$101,251.97 |
| TOTAL Sewer Operating | | | | | 299.75 |
| TOTAL Sewer Construction | | | | | - |
| Total Capital Reserve | | | | | - |
| TOTAL | | | | | \$101,551.72 |

Transferred by:

Authorized by:

POCONO TOWNSHIP CHECK LISTING Monday, April 16, 2018

| <u>Date</u> | <u>Check</u> | <u>Vendor</u> | <u>Memo</u> | <u>Amount</u> |
|-------------|--------------|-----------------------------------|---|---------------|
| 04/12/2018 | 56945 | NATIONWIDE 457 | April 2018 employee contribution | 5,389.06 |
| 04/12/2018 | 56946 | Teamster Local 773 | Police union dues | 1,142.00 |
| 04/12/2018 | 56947 | Teamster Local 773 | Non-police union dues | 480.00 |
| 04/12/2018 | 56948 | Acroprint Time Recorder Co. | Time Clocks - March | 119.00 |
| 04/12/2018 | 56949 | ARGS Technology, LLC | IT - Police/Township | 1,875.00 |
| 04/12/2018 | 56950 | Best Auto Service Center | Police Vehicle Repair | 189.99 |
| 04/12/2018 | 56951 | BIU of PA, Inc. | ZO/BIU Permits | 7,237.25 |
| 04/12/2018 | 56952 | Brodhead Creek Regional Authority | Sewer | 177.08 |
| 04/12/2018 | 56953 | Broughal & DeVito, L.L.P. | Legal | 5,564.38 |
| 04/12/2018 | 56954 | D.G. Nicholas Co. | Parts/Supplies | 144.53 |
| 04/12/2018 | 56955 | Davidheiser's Inc. | Speed testing | 112.00 |
| 04/12/2018 | 56956 | DCED | Municipal Code Training Account - 1st Quarter | 238.50 |
| 04/12/2018 | 56957 | DES | Recycling | 24.00 |
| 04/12/2018 | 56958 | Dunne Manning Stores, LLC | Vehicle Washes | 38.50 |
| 04/12/2018 | 56959 | Flamm, Walton Heimback & Lamm, PC | Legal - Labor matters | 955.50 |
| 04/12/2018 | 56960 | Gotta Go Potties, Inc | Portable Toilet - Mt. View | 85.00 |
| 04/12/2018 | 56961 | Highmark Inc. | Spending Account | 459.89 |
| 04/12/2018 | 56962 | HUNTER KEYSTONE PETERBILT | #12 Repair | 352.25 |
| 04/12/2018 | 56963 | Iannazzo, Mark | Uniform Allowance | 210.00 |
| 04/12/2018 | 56964 | Kimball Midwest | Drill bits/Supplies | 225.99 |
| 04/12/2018 | 56965 | Lawson Products | Drill/Supplies - PW | 224.92 |
| 04/12/2018 | 56966 | McCann Associates | Written & Oral Testing - Police Candidates | 11,149.85 |
| 04/12/2018 | 56967 | Metropolitan Telecommunications | Phones - Twp/Police/Parks | 899.88 |
| 04/12/2018 | 56968 | Network Fleet | GPS Service | 325.45 |
| 04/12/2018 | 56969 | Otto, Jamie Lynn | Cleaning - 04/07 to 04/14 | 550.00 |
| 04/12/2018 | 56970 | P & D Emergency Services | #90 Repair | 88.00 |
| 04/12/2018 | 56971 | PAPCO, Inc. | Deisel/Gas - Twp/Park/Police | 4,467.72 |
| 04/12/2018 | 56972 | Pocono Management Associates LLC | Contracted Services | 734.23 |

| <u>Date</u> | <u>Check</u> | <u>Vendor</u> | <u>Memo</u> | <u>Amount</u> |
|------------------------------|--------------|--|---|-------------------|
| 04/12/2018 | 56973 | Pocono Record | Advertising | 586.84 |
| 04/12/2018 | 56974 | PPL Electric Utilities | Township/Traffic/Park | 2,633.92 |
| 04/12/2018 | 56975 | Praxair Dist Mid-Atlantic | Cylinder Rental | 24.17 |
| 04/12/2018 | 56976 | RagnaSoft, Inc. | Planit - Service agreement - Police | 1,225.00 |
| 04/12/2018 | 56977 | Road Runner Food Mart | Gasoline and Diesel - 03/02 to 03/04/2018 | 670.82 |
| 04/12/2018 | 56978 | Sander Power Equipment Co. | Generator Rental | 950.00 |
| 04/12/2018 | 56979 | Sparkle Car Wash | Car Wash | 34.00 |
| 04/12/2018 | 56980 | Staples Business Credit | Office Supplies | 418.60 |
| 04/12/2018 | 56981 | Starr Uniform Center | Police Badges | 606.45 |
| 04/12/2018 | 56982 | The Pennsylvania State University | Supervisor Training Rath | 715.00 |
| 04/12/2018 | 56983 | Tulpehocken Mountain Spring Water Inc | Water | 107.10 |
| 04/12/2018 | 56984 | UNIFIRST Corporation | Carpets/Uniforms | 140.98 |
| 04/12/2018 | 56985 | Unum Life Insurance | Life Insurance | 1,860.22 |
| 04/12/2018 | 56986 | Wilson Products Compressed Gas Co. | Supplies | 7.00 |
| 04/12/2018 | 56987 | Wrecker International Inc. | Towing - Twp. Trucks | 800.00 |
| 04/12/2018 | 56988 | BIU of PA, Inc. | ZO Services | 800.00 |
| 04/12/2018 | 56989 | Cardmember Service | Winter storm supplies, PSATS, Verizon-Sargent | 1,209.53 |
| 04/13/2018 | 56990 | Banks Vacuum | Vacuum | void |
| 04/13/2018 | 56991 | Cardmember Service | PC Training/Toner/Prime membership | 347.00 |
| 04/13/2018 | 56992 | Cardmember Service | 20 DUJ Crime code books/Toner/Adaptor/APC Backups | 1,411.94 |
| 04/13/2018 | 56993 | Nauman Mechanical | Heating unit municipal building | 379.00 |
| 04/13/2018 | 56994 | Iannazzo, Mark | Uniform Allowance | 128.96 |
| 04/13/2018 | 56995 | Keystone Business Products | Copier - Police | 417.46 |
| 04/13/2018 | 56996 | Wilmington Trust, N.A. | TIF- Camelback | 140,502.62 |
| 04/13/2018 | 56997 | PA Municipal Health Insurance Coop | Health Insurance May | 61,601.50 |
| 04/13/2018 | 56998 | PA State Association of Twp. Supervisors | Drug Testing | 60.00 |
| 04/13/2018 | 56999 | Banks Vacuum | Vacuum | 109.99 |
| 04/13/2018 | 57000 | AFLAC | Supplemental Insurance | 431.92 |
| 04/13/2018 | 57001 | Stiff Oil Co | Heating oil | 1,400.04 |
| TOTAL General Fund \$ | | | | 263,040.03 |

| <u>Date</u> | <u>Check</u> | <u>Vendor</u> | <u>Memo</u> | <u>Amount</u> |
|------------------------------|--------------|------------------------------------|--|----------------------|
| Sewer Operating Fund | | | | |
| 04/13/2018 | 2125 | BLUE RIDGE COMMUNICATIONS | Phone/Internet Pump Station | 120.92 |
| 04/13/2018 | 2126 | Boucher & James, Inc. | PROJECT 1731017 Tannersville Exxon & Dairy Queen | 521.75 |
| 04/13/2018 | 2127 | CENTRAL CLAY PRODUCTS | 12" FLANGED PLUG VALVE | 4,059.00 |
| 04/13/2018 | 2128 | EEMA O&M Services Group, Inc. | SEWER O & M APRIL 2018 & 19 HRS EMERGENCY | 6,488.59 |
| 04/13/2018 | 2129 | ENQUIP COMPANY INC | KELLER FILTER BODY | 83.62 |
| 04/13/2018 | 2130 | METROPOLITAN TELECOMMUNICATIONS | PUMP STATION 5 PHONE LINE | 61.05 |
| 04/13/2018 | 2131 | PA One Call System, Inc | SEWER MAPPING | 117.16 |
| 04/13/2018 | 2132 | Pocono Management Associates LLC | CONTRACTED SERVICES | 2,770.71 |
| 04/13/2018 | 2133 | PPL Electric Utilities | SEWER ELECTRIC | 2,469.39 |
| 04/13/2018 | 2134 | MARY LOU GRIBBON | SEWER USER REFUND 2016/2017 | 937.53 |
| 04/13/2018 | 2135 | Broadhead Creek Regional Authority | Sewer Treatment May 2018 | 84,015.00 |
| 04/13/2018 | 2136 | BLUE RIDGE COMMUNICATIONS | Phone/Internet Pump Station | 61.22 |
| TOTAL Sewer Operating | | | | \$ 101,705.94 |

Sewer Construction Fund

TOTAL Sewer Construction Fund \$ -

Capital Reserve Fund

TOTAL Capital Reserve Fund \$ -

Amount

Memo

Vendor

Date Check

ESSA

| | | | | |
|-------------------------------|----|------------|-----------------|--|
| TOTAL General Fund | \$ | 263,040.03 | | |
| TOTAL Sewer Construction Fund | \$ | - | | |
| TOTAL ESSA TRANSFER | \$ | 263,040.03 | Transferred by: | |

Wayne Bank

| | | | | |
|----------------------|----|------------|----------------|--|
| Sewer Operating | \$ | 101,705.94 | Authorized by: | |
| Capital Reserve | \$ | - | | |
| TOTAL WAYNE TRANSFER | \$ | 101,705.94 | | |

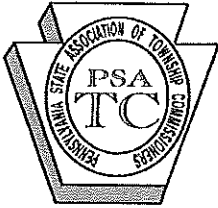

2018 PSATC ANNUAL CONFERENCE
 "Local Government...
 Honoring the Past...Shaping the Future"

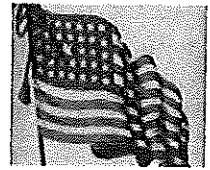

June 21, 22, 23 AND 24, 2018
 SKYTOP LODGE • SKYTOP, PA

John Kuntzelman
 President
 Home (717) 732-0364
 Cell (717) 443-1062
 jkuntzelman@eastpennsboro.net

Ginnie Anderson Kane
 Conference and
 Registration Chairman
 Home (717) 697-9544
 Cell (717) 903-0972
 andersonkane@aol.com

Sharon Shipman
 Co-Registration Chairman
 717-766-0756
 sshipman@uatwp.org

Lloyd Bucher
 Treasurer
 (717) 766-7192
 lwb130@yahoo.com

Robert Spandler
 Honorary Chairman
 robert421@comcast.net
 William Kane
 Honorary Chairman
 andersonkane@aol.com

2018 CONFERENCE REGISTRATION FORM
 DAILY CONFERENCE ATTENDEES

We are including an opportunity to attend the Conference for a day. Please indicate which day you will attend. You are responsible for the registration on the day you are attending. MAKE ALL CHECKS PAYABLE TO 2018 PSATC CENTRAL CONFERENCE COMM. SEND PAYMENT TO: Ginnie Anderson Kane, 503 Park Hills Drive, Mechanicsburg, PA 17055.

| TWO DAY ATTENDANCE (TWO NIGHTS) | PRICE | Cost | ONE DAY ATTENDANCE (ONE NIGHT) | PRICE | Cost |
|---------------------------------|----------|----------|--------------------------------|----------|----------|
| CIRCLE DAYS: THURS. FRI. SAT. | | | CIRCLE DAYS: THURS. FRI. SAT. | | |
| CONFERENCE REGISTRATION | \$150.00 | \$150.00 | CONFERENCE REGISTRATION | \$100.00 | \$100.00 |
| COMMISSIONER PACKAGE | \$664.00 | | COMMISSIONER PACKAGE | \$332.00 | |
| SPOUSE/GUEST PACKAGE | \$113.00 | | SPOUSE/GUEST PACKAGE | \$80.00 | |
| TOTAL | | | TOTAL | | |

Name: _____ Name on Badge: _____
 (MUST BE WORN AT ALL TIMES)

Township: _____ Twp. Phone Number: _____

Title: _____ Address: _____

City: _____ State: _____ Zip: _____

Phone: _____ Cell: _____

Email: _____

(Please include an email address for informational purposes only, to update program and conference information)

Spouse/Guest(s) Name on Badge: _____

Child/Children Name on Badge: _____

Special dietary/accessibility needs: NO YES SPECIFY: _____

PRE/POST CONFERENCE REGISTRATION *(Special price only for conference attendees)*

NAME: _____

EMAIL: _____

GUEST/CHILDREN'S NAME: _____

EARLY CHECK IN: WEDNESDAY, JUNE 20, 2018 _____

EXTEND STAY: SUNDAY, JUNE 24, 2018 _____

DOUBLE \$170.00 (INCLUDES BREAKFAST)

**MAKE CHECKS PAYABLE TO
 2018 PSATC CENTRAL CONFERENCE COMM.**

Registration Deadline May 10, 2018
 PLEASE RETURN PRE/POST CONFERENCE
 REGISTRATION WITH YOUR REGULAR
 REGISTRATION. THIS MUST BE HANDLED
 THROUGH THE REGISTRATION COMMITTEE FOR
 THE SPECIAL RATE AND ROOM ASSIGNMENTS.
Payment is your responsibility.

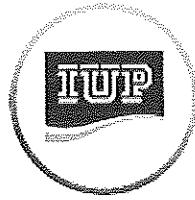

PA OSHA CONSULTATION PROGRAM



Since 1983, the Safety Sciences Department has been the officially designated agency in the Commonwealth of Pennsylvania for providing **FREE** occupational and health consultative services made available through federal regulations.



The program is designed to assist private-sector employers in the commonwealth in understanding and voluntarily complying with applicable safety/health regulations enforced by the federal Occupational Safety and Health Administration.

PA-OSHA CONSULTATION E-MAIL NEWSLETTER SIGN-UP

FREE CONSULTATION REQUEST FORM

Newsletter Archive

Previous newsletters available to download for your convenience.

Pennsylvania OSHA Consultation Program Brochure

Overview

Find out how to get started with the OSHA program and the benefits of participating. Also see our [OSHA Consultation brochure](#) and [Small Business Page](#).

Resources

Related websites and training information

Consultants and Staff

List of consultants for the PA/OSHA Consultation Program

Employer Benefits and Services

Employers who request service through the Consultation Program receive several benefits and services, many of which are summarized here. Included is also a video in which small businesses talk about the benefits of their state's OSHA consultation service.

PA OSHA Consultation Webinars

Webinars provided by the PA OSHA Consultation Program

Connect with Pennsylvania OSHA Consultation Program on Social Media

More IUP Social Media

College of Health and Human Services

Pennsylvania OSHA Consultation Office

57 South 9th Street

Suite 305

Indiana, PA 15701

Phone: 1-800-382-1241

Fax: 724-357-2385

Office Hours

Monday through Friday

8:00 a.m.–12:00 p.m.

4/12/2018

PA OSHA Consultation Program - Safety Sciences - IUP

1:00–4:30 p.m.

© 2007–18 Indiana University of Pennsylvania

1011 South Drive, Indiana, Pa. 15705 | 724-357-2100

POLICE REPORT FOR MARCH 2018

The following are the recorded activities of the Pocono Township Police Department for the month of March 2018. Also listed are the available recorded activities for 2018 year to date.

| | March 2018 | Y-T-D 2018 | | |
|---------------------------------|---------------|---------------|--|--|
| Incidents Investigated | 944 | 2426 | | |
| Burglary / Fire Alarms Answered | 83 | 211 | | |
| Motor Vehicle ACC | 53 | 165 | | |
| Assaults | 3 | 9 | | |
| Narcotics | 3 | 18 | | |
| Criminal Arrests | 19 | 65 | | |
| Theft | 17 | 51 | | |
| DUI alcohol/drug impaired | 9 | 28 | | |
| Mental Health | 9 | 18 | | |
| Vehicle Reports | 0 | 5 | | |
| Death Investigations | 2 | 5 | | |
| Assisting other agencies | 42 | 112 | | |
| Missing Persons | 0 | 3 | | |
| Traffic Citations Issued | 89 | 200 | | |
| Written Warnings | 188 | 486 | | |
| Traffic & Parking issues | 52 | 106 | | |
| 911 Hang-up Calls | 95 | 255 | | |

Mileage all Vehicles: 16,545

Income from Report Fees: \$521.60

**MONROE COUNTY TAX COLLECTION COMMITTEE
147 MUNICIPAL DRIVE
EAST STROUDSBURG, PENNSYLVANIA 18302**

April 4, 2018

Honorable David Millard
904B Orange Street
Berwick PA 18603

RE: House Resolution No. 291

Dear Representative Millard:

I am writing on behalf of the Monroe County Tax Collection Committee, Monroe County ("MCTCC") regarding House Resolution No. 291 Session of 2017 and amended on March 14, 2018.

The Delegates of the "MCTCC" are admittedly opposed to House Resolution No. 291 whereas the Pennsylvania Department of Revenue would replace the local earned income tax collection methods already in place.

Although we cannot presume what other tax collection committees are experiencing throughout the Commonwealth, the MCTCC is extremely pleased with Berkheimer as our EIT Tax Collector.

We hope you will consider our position opposing House Resolution No. 291 when it comes before you.

Sincerely,
Monroe Tax Collection Committee

Michele L. Clewell
Secretary/Treasurer

Cc: Representative Rosemary Brown
Representative Maureen Madden
Representative Jack Rader, Jr.
Senator John P. Blake
Senator Mario M. Scavello

Delaware Water Gap Borough • East Stroudsburg Borough • Mount Pocono Borough • Stroudsburg Borough • Barrett Township • Chestnuthill Township • Coolbaugh Township • Eldred Township • Hamilton Township • Jackson Township • Lehman Township • Middle Smithfield Township • Paradise Township • Pocono Township • Polk Township • Price Township • Ross Township • Smithfield Township • Stroud Township • Tobyhanna Township • Tunkhannock Township • East Stroudsburg Area School District • Pleasant Valley School District • Pocono Mountain School District • Stroudsburg Area School District •

Donna Asure

Subject: FW: Letter of support

On Apr 9, 2018, at 1:14 PM, Debra S. Raneri <draneri@northampton.edu> wrote:

Good Afternoon Ladies

NCC is in the process of writing a grant to AllOne Charities to receive funding to build a walking trail around our campus. I've included part of our rationale from the letter of intent that was already submitted:

The NCC Monroe campus walking trail will provide a walking and jogging path, approximately 1.7 miles in length, to be used by students for exercise and learning, buy faculty to teach and promote physical and health education, and by the community as a public resource to improve their well-being.

The walking trail will be open to the campus and wider community to engage in the low impact, healthy activity of walking. Regular walking is credited with lowering blood pressure by as much as eleven points and may reduce the risk of stroke by 20-40 percent. According to a study published in the *New England Journal of Medicine*, those who walked enough to meet physical activity guidelines (30 plus minutes 5 or more days/week) had a 30% lower risk of cardiovascular disease compared with those who did not walk regularly. The 2017 Community Health Needs Assessment Report commissioned by Lehigh Valley Hospital-Pocono confirms that walking can save lives. The report cites that mortality rates form heart disease and stroke are well above state and national averages in Monroe County where adult obesity and a sedentary lifestyle ae prevalent problems. These facts are further echoed in the Unites Way of Monroe County's Community Needs Assessment where physical health was also identified as one of the top five daily challenges for the 35-64 age group

I was wondering if the township could provide a letter of support for this project. The grant is due April 20th. Feel free to contact me with any questions

Dee Raneri, M. Ed
Associate Director of Community Education
Monroe Campus
570-369-1882

Pam Tripus

From: Municibid <support@municibid.com>
Sent: Friday, April 13, 2018 1:03 PM
To: Pam Tripus
Subject: Awesome! Your item sold - 2011 Ford Crown Victoria Listing #15608110



Congratulations! Your item ended successfully!



2011 Ford Crown Victoria listing # 15608110

Winning Bid Amount: \$1,325.00 USD

Municibid will take the buyers fee in a separate transaction from the bidders credit card.

Winning bidder: Peter Bajuz (username: system)

Email: [REDACTED]

Phone: [REDACTED]

The auction report for this item will be arriving shortly in an another email

Your Next Steps

1. **Contact the winning bidder**

Please contact **Peter Bajuz** ASAP to arrange payment and pickup. If the bid is waiting approval by your agency, please contact the bidder to let them know when they can expect a decision.

You can also use our Municibid message system to contact the bidder. [Use Municibid Messaging](#)

2. **Create an invoice for this item**

3. **Mark the Item Paid**

After the item has been paid for and picked up, don't forget to mark it paid. [How do I do this?](#)

Pam Tripus

From: Municibid <support@municibid.com>
Sent: Friday, April 13, 2018 2:01 PM
To: Pam Tripus
Subject: Awesome! Your item sold - 2013 Ford Police Interceptor Listing #15609261



Congratulations! Your item ended successfully!



2013 Ford Police Interceptor listing # 15609261

Winning Bid Amount: \$4,756.00 USD

Municibid will take the buyers fee in a separate transaction from the bidders credit card.

Winning bidder: michael bearer (username: 1badtitan)

Email: [REDACTED]

Phone: [REDACTED]

The auction report for this item will be arriving shortly in an another email

Your Next Steps

1. **Contact the winning bidder**

Please contact **michael bearer** ASAP to arrange payment and pickup. If the bid is waiting approval by your agency, please contact the bidder to let them know when they can expect a decision.

You can also use our Municibid message system to contact the bidder. [Use Municibid Messaging](#)

2. **Create an invoice for this item**

3. **Mark the Item Paid**

After the item has been paid for and picked up, don't forget to mark it paid. [How do I do this?](#)



Hunter Truck Sales and Service H546
 1328 Golden Slipper Road 025-101

Pocono Township
 112 Township Dr

Bartonsville, Pennsylvania United States 18321
 Phone: (570) 688-2400
 Fax:
 Email: ldomenico@poconopeterbilt.com

Tannersville, Pennsylvania United States 18372
 Phone: (570) 888-4344
 Fax:
 Contact Email:
 Prepared for:

Customer Quote

Equipment

| | |
|-------------------------------------|-----------|
| Quantity Ordered: | 1 |
| Truck Price: | \$140,241 |
| Dealer Options: | \$0 |
| Equipment List Price: | \$140,241 |
| Surcharges Not Subject to Discount: | \$0 |
| Options Not Subject to Discount: | \$0 |
| Factory Freight Cost: | \$2,200 |

Total Equipment Price: \$142,441

NET Sale Price: \$93,991

Miscellaneous

| | | |
|-------------------------------|-----|-----|
| FET Tire Credit: | \$0 | \$0 |
| Net Chassis FET: | | \$0 |
| State Tax: | | \$0 |
| Body/Trailer/Accessories FET: | | \$0 |
| Fees: | | \$0 |
| Other: | | \$0 |

Quotation Total: \$93,991

Unpublished options may require review/approval.
 Dimensional and performance data for unpublished options may vary from that displayed in PROSPECTOR.

| | | | | |
|-----------------|-----------------------|-----------------|-----------------|-----------|
| Printed: | 03/08/2018 3:35:21 PM | Complete | Model Number: | Model 348 |
| Effective Date: | Jul 1, 2017 | | Quote/DTPO/CO: | Q81954413 |
| Prepared by: | Louis J Domenico III | | Version Number: | 35.20 |



Hunter Truck Sales and Service H546
1328 Golden Slipper Road

Pocono Township
112 Township Dr

Bartonsville, Pennsylvania United States 18321
Phone: (570) 688-2400
Fax:
Email: ldomenico@poconopeterbilt.com

Tannersville, Pennsylvania United States 18372
Phone: (570) 888-4344
Fax:
Contact Email:
Prepared for:

Vehicle Summary

| Unit | | Chassis | |
|-------------------------|-----------------|----------------------------|-------|
| Model: | Model 348 | Fr Axle Load (lbs): | 16000 |
| Type: | Full Truck | Rr Axle Load (lbs) | 23000 |
| Description: | 10' Single axle | G.C.W. (lbs): | 39000 |
| Application | | Road Conditions: | |
| Intended Serv.: | Snowplow | Class A (Highway) | 95 |
| Commodity: | Other Commodity | Class B (Hwy/Mtn) | 0 |
| Body | | Class C (Off-Hwy) | 5 |
| Type: | End Dump | Class D (Off-Road) | 0 |
| Length (ft): | 10 | Maximum Grade: | 6 |
| Height (ft): | 10.5 | Wheelbase (in): | 154 |
| Max Laden Weight (lbs): | 3500 | Overhang (in): | 45.8 |
| Trailer | | Fr Axle to BOC (in): | 69.8 |
| No. of Trailer Axles: | 0 | Cab to Axle (in): | 84.2 |
| Type: | | Cab to EOF (in): | 130.0 |
| Length (ft): | 0 | Overall Comb. Length (in): | 266 |
| Height (ft): | 0.0 | Special Req. | |
| Kingpin Inset (in): | 0 | United States Registry | |
| Corner Radius (in): | 0 | | |
| Restrictions | | | |
| Length (ft): | 40 | | |
| Width (in): | 102 | | |
| Height (ft): | 13.5 | | |

Approved by: _____

Date: _____

Note: All sales are F.O.B. designated plant of manufacture.

| | |
|-------------------------|--|
| PACCAR FINANCIAL | Ask your dealer for a quote today, or visit our website @ www.paccarfinancial.com . |
| | PACCAR Financial offers innovative finance, lease and insurance programs customized to meet your needs. |

Unpublished options may require review/approval.
Dimensional and performance data for unpublished options may vary from that displayed in PROSPECTOR.

| | | | | |
|-----------------|-----------------------|-----------------|-----------------|-----------|
| Printed: | 03/08/2018 3:35:38 PM | Complete | Model Number: | Model 348 |
| Effective Date: | Jul 1, 2017 | | Quote/DTPO/CO: | Q81954413 |
| Prepared by: | Louis J Domenico III | | Version Number: | 35.20 |



Hunter Truck Sales and Service H546
1328 Golden Slipper Road

Pocono Township
112 Township Dr

Bartonsville, Pennsylvania United States 18321
Phone: (570) 688-2400
Fax:
Email: Idomenico@poconopeterbilt.com

Tannersville, Pennsylvania United States 18372
Phone: (570) 888-4344
Fax:
Contact Email:
Prepared for:

| | Description | Weight |
|------------------------------|--|--------|
| Base Model | | |
| | Model 348 | 10,610 |
| | Other Commodity | 0 |
| | Snowplow Truck which is configured for mounting a snowplow to the front. May also have dump or other body. | 0 |
| | End Dump | 0 |
| | United States Registry | 0 |
| Configuration | | |
| | Not Applicable Secondary Manufacturer | 0 |
| Frame & Equipment | | |
| | 10-11/16in Steel Rails to 285in 1/2in Rail Thickness; 10.6875 x 3.5 x 0.5 Dimension. 2,683,000 lbs. RBM; Yield Strength: 120,000 psi. Section Modulus: 22.35 cubic inches. Weight: 2.35 lbs/inch pair | 569 |
| | Zinc Coated Anti Corrosion Treated Frame Rails Requires Frame Rail Code. Zinc Phosphate coating will replace the standard frame rail primer and provide added corrosion prevention for your customer's operating in severe conditions or in climates where vehicle rust is common. | 0 |
| | 154in Wheelbase | 0 |
| | Three-Piece Crossmembers | 0 |
| | 27.8in Bumper Extension without Adapter Includes Stationary Grille. Requires FEPTO Bumper. | 0 |
| | EOF Square without Xmbr For use with body builder installed crossmember. | 0 |
| | Omit Rear Mudflaps and Hangers | 0 |

Front Axle & Equipment

Unpublished options may require review/approval.
Dimensional and performance data for unpublished options may vary from that displayed in PROSPECTOR.

| | | | | |
|-----------------|-----------------------|-----------------|-----------------|-----------|
| Printed: | 03/08/2018 3:35:38 PM | Complete | Model Number: | Model 348 |
| Effective Date: | Jul 1, 2017 | | Quote/DTPO/CO: | Q81954413 |
| Prepared by: | Louis J Domenico III | | Version Number: | 35.20 |



| Description | Weight |
|--|--------|
| Dana Spicer D2000F 20,000 lb, 3.5 in. Drop Factory front axle alignment to improve handling & reduce tire wear. Zerk fittings on tie rod ends, king pins, & draglink ball joints for ease of maintenance & help extend service life of components. Cognis EMGARD® FE 75W-90 synthetic axle lube provides over 1% fuel economy improvement. Reduces wear & extends maintenance intervals, resulting in increased uptime. Provides improved fluid flow to protect components in extreme cold conditions & withstand the stress from high temperatures, extending component life. | 152 |
| Taper Leaf Springs, Shocks 16,000 lb Standard with Heavy Resistance Shocks. | 66 |
| Power Steering TRW THP60 Dual For use with 16,000 to 20,000 lb. axle ratings. Glidekote splines on steering shaft extend service life of components. | 54 |
| Power Steering Reservoir Frame Mounted w/Cooler | 2 |
| PHP10 Iron PreSet Hubs | 0 |
| Bendix Air Cam Front Drum Brakes 16.5x6 Includes automatic slack adjusters & outboard mounted brake drums. | 0 |
| Gusseted Cam Brackets, Steer Axle | 0 |

Rear Axle & Equipment

| | |
|---|----|
| Dana Spicer S23-190 23,000 lb Laser factory axle alignment to improve handling & reduce tire wear. Magnetic rear axle oil drain plug captures & holds any metal fragments in drive axle lube to extend service life. Parking brakes on all drive axles for optimal performance. Cognis EMGARD® FE 75W-90 synthetic axle lube provides over 1% fuel economy improvement. Reduces wear & extends maintenance intervals, resulting in increased uptime. Provides improved fluid flow to protect components in extreme cold conditions & withstand the stress from high temperatures, extending component life. | 75 |
| PHP10 Iron PreSet Hubs | 0 |
| Standard Stroke Parking Brakes Drive Axle(s). Not for use on U.S. or Canada Tractors, other than Car Carriers. | 0 |
| Diff Lock Rear-Rear Or Single Drive Axle (Air Rocker Switch occupies the space of one gauge) | 24 |
| Rear Brake Camshaft Reinforcement | 9 |
| Gusseted Cam Brackets, Drive Axle(s) | 2 |
| SBM Valve Full trucks require a spring brake modulation (SBM) system for emergency braking application. This system requires an SBM valve and a relay valve with spring brakes on the rear axles. The SBM valve allows the foot valve to operate the rear axle spring brakes if a failure exists in the rear air system. | 0 |
| Stability System Not Selected or Not Available | 0 |

Unpublished options may require review/approval.

Dimensional and performance data for unpublished options may vary from that displayed in PROSPECTOR.

| | | | | |
|-----------------|-----------------------|-----------------|-----------------|-----------|
| Printed: | 03/08/2018 3:35:38 PM | Complete | Model Number: | Model 348 |
| Effective Date: | Jul 1, 2017 | | Quote/DTPO/CO: | Q81954413 |
| Prepared by: | Louis J Domenico III | | Version Number: | 35.20 |



| Description | Weight |
|---|--------|
| Anti-Lock Braking System (ABS) 4S4M ABS-6. Includes air braking system. | 0 |
| Synthetic Axle Lubricant All Axles Peterbilt heavy duty models include Fuel Efficient Cognis EMGARD FE75W-90 which provides customers performance advantages over current synthetic lubricants with reduced gear wear and extended maintenance intervals, resulting in increased uptime. In addition, the lubricant provides improved fluid flow to protect gears in extreme cold conditions and withstand the stress from high temperatures, extending component life. | 0 |
| Single Drive Axle (Model 348) | 0 |
| Bendix Air Cam Rear Drum Brakes 16.5x7 Includes Automatic Slack Adjusters & Outboard Mounted Brake Drums. | 0 |
| Ratio 5.57 Rear Axle | 0 |
| Peterbilt Air Trac 23,000 lb Light Weight | 0 |
| Air Springs, Internal Bumpers Air Trac / Air Leaf suspensions | 0 |
| Dash Mtd Dump Switch With Indicator Light For suspension | 2 |

Engine & Equipment

| | |
|---|---|
| PACCAR PX-9 350@2000 GOV@2200 1150@1400 Productivity (2017 Emissions) Includes alum flywheel housing, cruise control, and J1939 provisions (provides an interface point for the Electronic Service Analysis-ESA and other PACCAR approved diagnostic tools). Chevron Delo LE SAE 10W30 engine oil is specially formulated for new low emissions engines. Magnetic engine oil drain plug captures and holds any metal fragments in engine oil to extend service life. N21320 N205 120..Standard Maximum Speed Limit [LSL] N21330 N207 0....Expiration Distance N21340 P005 120..Hard Maximum Speed Limit N21350 P001 65...Maximum Accelerator Pedal Vehicle Speed N21370 P059 65...Maximum Cruise Speed N21400 N203 252..Reserve Speed Function Reset Distance N21410 N202 0....Maximum Cycle Distance N21420 N206 10...Maximum Active Distance N21430 N201 0....Reserve Speed Limit Offset N21440 P015 YES..Engine Protection Shutdown N21450 P026 NO...Gear Down Protection N21460 P046 1400.Max PTO Speed N21470 P062 NO...Cruise Control Auto Resume N21480 P068 YES..Auto Engine Brake in Cruise N21500 N209 0....Expiration Distance N21510 P520 YES..Enable Idle Shutdown Park Brake Set N21520 P030 5....Timer Setting N21530 P233 YES..Enable Impending Shutdown Warning N21540 P234 60...Timer For Impending Shutdown Warning N21550 P516 35...Engine Load Threshold N21570 P031 YES..Idle Shutdown Manual Override | 0 |
|---|---|

Unpublished options may require review/approval.
Dimensional and performance data for unpublished options may vary from that displayed in PROSPECTOR.

| | | | | |
|-----------------|-----------------------|-----------------|-----------------|-----------|
| Printed: | 03/08/2018 3:35:38 PM | Complete | Model Number: | Model 348 |
| Effective Date: | Jul 1, 2017 | | Quote/DTPO/CO: | Q81954413 |
| Prepared by: | Louis J Domenico III | | Version Number: | 35.20 |



| Description | Weight |
|---|--------|
| N21590 P230 YES..Enable Hot Ambient Automatic Overrule | 0 |
| N21610 P172 43...Low Ambient Temperature Threshold | 0 |
| N21620 P173 60...Intermediate Ambient Temperature Threshold | 0 |
| N21630 P171 77...High Ambient Temperature Threshold | 0 |
| Engine Idle Shutdown Timer Enabled | 0 |
| Enable EIST Ambient Temp Overrule | 0 |
| Eff EIST NA Expiration Miles | 0 |
| Effective VSL Setting NA | 0 |
| Belly Pan | 35 |
| CARB Engine Idling Compliance PACCAR PX-7, PX-9 and MX, Cummins ISL, ISM and ISX diesel engines will include the required factory installed serialized sticker on the drivers door to identify them as meeting the NOx idling standard. | 0 |
| 200 Amp Alternator, Standard Brush | 0 |
| Immersion Type Block Heater 110-120V Standard location is center left hand under cab and includes a weather-proof cover that protects the receptacle. This pre-heater keeps the coolant in the engine block from freezing when the engine is not running. | 2 |
| PACCAR 12V Starter | 0 |
| 3 PACCAR Premium 12V Dual Purpose Batt 2190 CCA Threaded stud type terminal. Stranded copper battery cables are double aught (00) or larger to reduce resistance. | 62 |
| Kissling Battery Disconnect Switch Mounted on battery box | 3 |
| 2-Speed Fan Clutch For Frequent Start/Stops | 0 |
| 18.7 CFM Air Compressor N/A X15. Furnished on engine. Teflon lined stainless steel braided compressor discharge line. | 0 |
| C-Brake By Jacobs, PX-9 | 90 |
| Spin-On Fuel/Water Separator | 0 |
| No Fluid Heat Option for Fuel Filter | 0 |
| No Electric Heat Option for Fuel Filter | 0 |
| Engine Protection Shutdown Includes oil pressure, oil temperature, coolant temperature, and intake manifold temperature. | 0 |

Unpublished options may require review/approval.
Dimensional and performance data for unpublished options may vary from that displayed in PROSPECTOR.

| | | | | |
|-----------------|-----------------------|-----------------|-----------------|-----------|
| Printed: | 03/08/2018 3:35:38 PM | Complete | Model Number: | Model 348 |
| Effective Date: | Jul 1, 2017 | | Quote/DTPO/CO: | Q81954413 |
| Prepared by: | Louis J Domenico III | | Version Number: | 35.20 |



| Description | Weight |
|--|--------|
| High Efficiency Cooling System Cooling module is a combination of steel and aluminum components, with aluminum connections to maximize performance and cooling capability. Silicone radiator & heater hoses enhance value, durability, & reliability. Constant tension band clamps reduce leaks. ClimaTech extended life coolant extends maintenance intervals which reduces maintenance costs. Anti-freeze effective to -30 degrees F helps protect the engine. Low coolant level sensor warns of low coolant condition to prevent engine damage. Radiator Size by Model: 587: 1330 sq in, 579/367 FEPTO 1325 sq in, 567/365/367: 1440 sq in, 384/386: 1301 sq in, 365 FEPTO: 1184 sq in, 389/367 HH: 1669 sq in, 348: 1000 sq in, 320: 1242 sq in. | 0 |
| Radial Seal, Dry Type Air Cleaner, Frontal Air Intake. Molded rubber air intake connections with lined stainless steel clamps seal to prevent contaminants in air intake. | 0 |
| Exhaust Single RH Side Of Cab DPF/SCR RH Under Cab (2017). | 29 |
| Curved Tip Standpipe(s) | 0 |
| 24in Ht, 5in Dia Chrome, Clear Coat Standpipe(s) | 0 |

Transmission & Equipment

| | |
|--|-----|
| Allison 3000 RDS-P Transmission, Gen 5 Rugged Duty Series. Includes Rear Transmission Support except on MX engines, TranSynd Automatic Transmission Fluid, and Water Oil Heat Exchange. Also includes features that monitor the transmission fluid, filter and clutch condition. Will display percent life remaining for the transmission fluid, filter and clutches on the shift selector. This information may be displayed using the Mode and Up and Down buttons. A wrench icon will also be included to indicate when the transmission fluid, filter or clutches need servicing. (Suited for vehicles operating on/off highway and/or requiring PTO operation) Forward Ratios: 1st-3.49, 2nd-1.86, 3rd-1.41, 4th-1.00, 5th-0.75, 6th-0.65 / Reverse Ratios: DR-(5.03) | 110 |
| 1760 HD Driveline, 1 Midship Bearing | -20 |
| (1) Dash Mounted Single Acting Air PTO Control Standard with PTO engaged indicator light on Class 8 units. Occupies the space of one gauge. Specing PTO switch does not ensure the PTO will fit. | 0 |
| Allison FuelSense Max: Base Economy Includes 5th Generation Controls, EcoCal, Dynamic Shift Sensing, Neutral at Stop and Acceleration Rate Management. For additional information see Product Portfolio. | 0 |
| Auto Neutral Activates With Parking Brake | 0 |
| Allison 6-Speed Configuration, Close Ratio Gears 3000 Series Transmissions | 0 |
| Seat Mounted Lever Shifter | 0 |

Unpublished options may require review/approval.
Dimensional and performance data for unpublished options may vary from that displayed in PROSPECTOR.

| | | | | |
|-----------------|-----------------------|-----------------|-----------------|-----------|
| Printed: | 03/08/2018 3:35:38 PM | Complete | Model Number: | Model 348 |
| Effective Date: | Jul 1, 2017 | | Quote/DTPO/CO: | Q81954413 |
| Prepared by: | Louis J Domenico III | | Version Number: | 35.20 |



| Description | Weight |
|--|--------|
| Rolling Direction Change Shift Inhibit Feature Allison Transmissions. A programmable feature that keeps the transmission from shifting from Drive to Reverse or from Reverse to Drive above a preset speed. This wireless function is enabled when a switch is closed to complete the circuit between input wire 101 and ground. Frequently the function is interfaced with a switch indicating activation of another vehicle function, such as application of the service brakes. When the function is enabled, the TCM will recognize the request for a direction change shift, Reverse-to-Drive or Drive-to-Reverse. If all other operating conditions are acceptable, the TCM will command the requested shift. The enable remains in effect until the switch is opened, followed by the selection of a different direction, Reverse or Drive, at the shift selector. This could be used for doc spotters and refuse. If the function is not enabled, any shift which results in a change of direction is inhibited. | 0 |
| Air & Trailer Equipment | |
| Bendix AD-IS EP Air Dryer with Heater And Coalescing Filter; Extended Purge | 6 |
| Pull Cords All Air Tanks | 0 |
| Nylon Chassis Hose | 0 |
| Aluminum Painted Air Tanks All air tanks are aluminum with painted finish except when Code 4543330 Polish Aluminum Air Tanks is also selected (then exposed air tanks outside the frame rails will be polished aluminum). Peterbilt will determine the optimal size and location of required air tanks. Narratives requesting a specific air tank size or location will not be accepted for factory installation. See ECAT to determine number or location of air tanks installed. | -45 |
| Body Connections 5ft BOC Junction Box contains light and power circuits for Body Connections located 5ft from BOC. | 4 |
| Tires & Wheels | |
| FF: GY 18ply 315/80R22.5 G291 Diameter = 42.3 inches; SLR = 19.7 inches. Compares to Michelin XZA2 Energy, Michelin XZA1 and Bridgestone R294 tread. | 40 |
| RR: GY 16ply 11R22.5 G182 RSD GHG Diameter= 42.1 inches; SLR= 19.6 inches | 28 |
| Code-rear Tire Qty 04 | 0 |
| FF: Alcoa 89U637 22.5X9.00 Clean Buff Finish Aluminum, Ultra ONE wheels with MagnaForce alloy. | -36 |
| RR: Alcoa 883677 22.5X8.25 Clean Buff Finish Aluminum | -88 |
| Code-rear Rim Qty 04 | 0 |
| FF: Polish Wheels, Outer Surface, Sgl/Tdm Steer Polish outer surface of outer wheel. Without chrome wheel nuts. | 0 |
| RR: Polish Wheels, Outer Surface, Single Drive Without chrome wheel nuts. Polish outer surface of outer wheel. | 0 |

Unpublished options may require review/approval.
 Dimensional and performance data for unpublished options may vary from that displayed in PROSPECTOR.

| | | | | |
|-----------------|-----------------------|-----------------|-----------------|-----------|
| Printed: | 03/08/2018 3:35:38 PM | Complete | Model Number: | Model 348 |
| Effective Date: | Jul 1, 2017 | | Quote/DTPO/CO: | Q81954413 |
| Prepared by: | Louis J Domenico III | | Version Number: | 35.20 |



| | Description | Weight |
|---------------------------------|--|--------|
| | Schrader 1126 Double Seating Extensions | 0 |
| | On Tire Valve Stems | |
| | FF: Dura-Bright Finish | 0 |
| | Outer Surface of Outer Wheel, Includes Wheel Guards, Requires Polished Option | |
| | RR: Dura-Bright Finish-Single Axle | 0 |
| | Outer Surface of Outer Wheel, Includes Wheel Guards, Requires Polished Option. | |
| Fuel Tanks | | |
| | 26 in Aluminum 70 Gallon Fuel Tank LH BOC | 119 |
| | Paddle handle filler cap with threadless filler neck. Top draw fuel plumbing reduces chance of introducing air into the fuel system during low fuel level conditions due to the central placement of fuel pickup tube. Wire braid fuel lines increase durability & reduce potential for leaks. | |
| | Location LH BOC 70 Gallon | 0 |
| | Polish (1) Aluminum Fuel Tank | 0 |
| | Polish All Fuel / Hydraulic Tank Straps | 0 |
| | Does not apply to Rectangular Def Tank straps. | |
| | Locking Fuel Tank Cap(s) | 0 |
| | DEF Tank Mounted LH BOC | 0 |
| | Models 210, 220 and 320 mounted LH cab fender. | |
| | Standard DEF To Fuel Ratio 2:1 Or Greater | 0 |
| | Polished Stainless Steel Cover For DEF Tank | 0 |
| | DEF Tank Small | 0 |
| Battery Box & Bumper | | |
| | Aluminum Battery Box LH Under Cab, Non-Slip Step | -55 |
| | Includes diamond pattern block shaped cover in traditional/vocational models and a smooth finish tapered cover on aerodynamic models. | |
| | Rubber Battery Pad In Bottom Of (1) Battery Box | 2 |
| | Mat in box that holds batteries only | |
| | Polishing Battery/Tool Box(s), Aftertreatment Cab | 0 |
| | Entry complete | |
| | Heavy Duty Battery Box Step Reinforcement | 2 |
| | Aftertreatment RH U/C ALUMINUM Non-Slip Cab Entry | 0 |
| | Step. DPF/SCR for diesel engines, catalyst for natural gas engines. On Models 579 specifying chassis fairings, the box will be aerodynamic. | |
| | Steel Bumper Swept Back Painted Black, With FEPTO | 90 |
| | (2) Tow pin holes and step plates on top of bumper | |
| Cab & Equipment | | |
| | Alum Cab 108in BBC Metton Hood w/Bright Crown | 0 |
| | Includes view window RH door and convex mirror over RH door. | |

Unpublished options may require review/approval.
Dimensional and performance data for unpublished options may vary from that displayed in PROSPECTOR.

| | | | | |
|-----------------|-----------------------|-----------------|-----------------|-----------|
| Printed: | 03/08/2018 3:35:38 PM | Complete | Model Number: | Model 348 |
| Effective Date: | Jul 1, 2017 | | Quote/DTPO/CO: | Q81954413 |
| Prepared by: | Louis J Domenico III | | Version Number: | 35.20 |



| Description | Weight |
|---|--------|
| Severe Service Cab Package #1 Includes Aluminum side skins, aluminum rear skin, steel windshield mask, steel firewall, and steel front floor sheet on all cabs, and additional reinforcement structure on the back wall of the day cab. | 39 |
| Thermal Insulation Package in Cab Includes thick, closed-cell foam in floor, special mylar-faced foam in walls and roof structure. | 2 |
| Rubber Fender Lips 2 Inch Wide | 8 |
| Peterbilt UltraRide Driver Seat | 0 |
| Peterbilt UltraRide Passenger Seat | 0 |
| Seat Skirt - All Eligible Air Seats | 2 |
| Drivers Armrests - LH & RH Required in Model 587 with Evolution LX seats, optional with Evolution ST and Rolltek Seats. | 4 |
| Passenger Armrest - LH only Required with Evolution LX seats, optional with Evolution ST Seats. | 2 |
| Black Seat Color ipo Standard Color | 0 |
| Air Ride Driver | 0 |
| High Back Driver | 0 |
| Vinyl Driver | 0 |
| Non-Air Ride Passenger | 0 |
| High Back Passenger | 0 |
| Vinyl Passenger | 0 |
| Manifest Pouch on Rear Cab Wall | 0 |
| Adjustable Steering Column - Tilt/Telescope | 11 |
| Steering Wheel with Peterbilt Logo Steering Wheel with embossed Peterbilt logo over horn button. | 0 |
| Interior Grey/Black Includes rugged charcoal instrument panels, glare-resistant gray dash, black bezels on gauges, (2) power ports, monochromatic molded door pads with durable in-mold color, gray molded back wall, 18 inch 4-spoke soft-touch steering wheel, soft-touch steering column cover, power lift passenger window, extruded rubber floor covering, header-mounted dome light, foot well lighting, integrated "dead pedal", (4) inside entry grab handles, (2) inside sunvisors, (2) coat hooks, (2) cup holders and map bin in dash. | 0 |
| Extended Rear Window ipo Std Window-Day Cab The extended rear window protrudes two inches more than the standard conventional rear cab window. Take this into consideration when determining your loadspace. | 0 |
| Day Cab Rear Window | 0 |
| One Piece Curved Windshield | 0 |

Unpublished options may require review/approval.
Dimensional and performance data for unpublished options may vary from that displayed in PROSPECTOR.

| | | | | |
|-----------------|-----------------------|-----------------|-----------------|-----------|
| Printed: | 03/08/2018 3:35:38 PM | Complete | Model Number: | Model 348 |
| Effective Date: | Jul 1, 2017 | | Quote/DTPO/CO: | Q81954413 |
| Prepared by: | Louis J Domenico III | | Version Number: | 35.20 |



| Description | Weight |
|--|--------|
| Combo Fresh Air Heater/Air Conditioner With radiator mounted condenser, dedicated side window defrosters, Bi-Level Heater/Defroster Controls, 54,500 BTU/HR, and silicone heater hoses. | 0 |
| Peterbilt Comfort Control - Cab | 6 |
| Outside Sunvisor - Stainless Steel Not available with 2.1M high roof sleeper or furnished by owner sleeper. | 4 |
| Mirrors SSTL Each Side Heated and Motorized with Switch on Door. Right Click on option to See Picture in Product Portfolio. | 2 |
| (2) Convex 8 Inch SS Mirrors Center mounted under mirror bracket. If rear view mirrors are heated, the convex mirrors will be heated. Option includes dual door stops. | 4 |
| Power Package Includes power door locks and power windows. | 0 |
| Polished Lower Mirror Bracket Covers | 0 |
| (2) Air Horns 24.5in Chrome - Round w/Horn Shield | 16 |
| Standard Speaker Package For Cab (2) Speakers | 4 |
| ConcertClass Without CD, Includes BT Phone and Audio, AM/FM, WB, USB and MP3. | 10 |
| CB Terminals/Wiring Mtd Under Header | 0 |
| (1) 48 Inch CB Antenna | 0 |
| CB Antenna Mounting, LH Mirror | 0 |
| Radio Antenna Mounted on LH Mirror Bracket | 0 |
| Plug-In Auto Reset Circuit Breaker in place of fuses in junction box. | 0 |
| Peterbilt Electric Windshield Wipers With Intermittent Feature. | 0 |
| CabMate Cab Air Suspension Mfg by Link. The class 8 conventionals (except Model 348) includes (2) airbags, (2) shock absorbers, (1) leveling valve, radius rod, and height limiter. The Models 330, 337, and 348 includes (1) airbag and (1) shock absorber. | 15 |
| Triangle Reflector Kit Shipped Loose | 13 |
| Fire Extinguisher; Cab Mounted Hazmat approved UL listed/rated ABC. | 8 |
| Backup Alarm (107dB) | 3 |
| Main Transmission Oil Temperature Gauge Located in Driver Information Display | 0 |
| Air Restriction Indicator Mounted on air cleaner, intake piping, or firewall. | 0 |

Unpublished options may require review/approval.
Dimensional and performance data for unpublished options may vary from that displayed in PROSPECTOR.

Printed: 03/08/2018 3:35:38 PM
Effective Date: Jul 1, 2017
Prepared by: Louis J Domenico III

Complete

Model Number: Model 348
Quote/DTPO/CO: Q81954413
Version Number: 35.20



| Description | Weight |
|--|--------|
| Buzzer On Air Suspension Dump Valve Requires dash mounted dump valve (1922260) | 0 |
| Bright Bezel Gauges | 0 |
| (2) Additional Electric Switches Without Wiring | 0 |
| Main Instrumentation Panel, Graphics Display Includes speedometer with tripodometer, tachometer with hourmeter and outside air temperature display, voltmeter, engine oil pressure, engine coolant temperature, fuel level, primary and secondary air pressure gauges. Includes standard warning light package: high water temperature, low oil pressure, and low air pressure warning lights w/audible alarms, high beam, turn signal, low fuel, parking brake, and ice warning indicators; seat belt reminder; rocker switches with long-life LED indicators; multi-function turn stalk with flash-to-pass feature (night mode flashes headlights and marker lights; day mode flashes headlights only), intermittent windshield wiper and headlamp beam control. Hydraulic braked trucks do not include air pressure gauges. | 0 |
| Headlights Composite Fender Mounted Integral Park, Turn, and Side Marker | 0 |
| (5) Marker Lights, Aero LED Light Emitting Diodes | 0 |
| Switch And Wiring For F/O Beacon/Strobe 10ft coiled wire BOC/BOS at rear sill. | 2 |
| Daytime Running Lights (Required on Canadian units) | 0 |
| (2) Addl Dome/Reading Lights, Ceiling Mounted | 0 |
| LED Stop/Turn/Tail/Backup Bracket mounted LH/RH EOF | 2 |
| Moveable EOF Xmbr For Mounting Taillights Square EOF with or without EOF xmbr. | 10 |
| (1) F/O Load Light, Switch & 10ft Wire Coil Under / in cab / sleeper | 2 |

Paint

| | |
|--|---|
| (1) Color Axalta Two Stage - Cab/Hood Base Coat/Clear Coat N85020 A - 791801EY JADE MIST GRE N85400 HOOD TOP 791801EY JADE MIST GRE N85500 CAB ROOF 791801EY JADE MIST GRE N85200 FRAME N0001EA BLACK N85700 BUMPER N0001EA BLACK N85300 FENDER 791801EY JADE MIST GRE | 0 |
|--|---|

Options Not Subject To Discount

| | |
|---|---|
| Peterbilt Class 7 Standard Coverage 1 year/Unlimited Miles/km | 0 |
| PACCAR PX-9 Standard Coverage 2 yrs/250,000 mi (402,336 km)/6,250 hrs | 0 |

Unpublished options may require review/approval.

Dimensional and performance data for unpublished options may vary from that displayed in PROSPECTOR.

| | | | | |
|-----------------|-----------------------|-----------------|-----------------|-----------|
| Printed: | 03/08/2018 3:35:38 PM | Complete | Model Number: | Model 348 |
| Effective Date: | Jul 1, 2017 | | Quote/DTPO/CO: | Q81954413 |
| Prepared by: | Louis J Domenico III | | Version Number: | 35.20 |



| Description | | Weight |
|--|--|-----------|
| Miscellaneous | 2017 EPA Emissions Engine Warranty Only | 0 |
| | Presentation Created Using Featured Spec For Model | 0 |
| Promotions | PA COSTARS N95140 OAR0 | 0 |
| Total Adjusted Price (W/O Freight & Warranty & Surcharges) | | \$140,241 |
| Freight Charge | | \$2,200 |
| Options Not Subject to Discount | | \$0 |
| Surcharges Not subject to Discount | | \$0 |
| Total Weight | | 12112 |

Prices and Specifications Subject to Change Without Notice.

Unpublished options may require review/approval.
Dimensional and performance data for unpublished options may vary from that displayed in PROSPECTOR.

| | | | | |
|-----------------|-----------------------|-----------------|-----------------|-----------|
| Printed: | 03/08/2018 3:35:38 PM | Complete | Model Number: | Model 348 |
| Effective Date: | Jul 1, 2017 | | Quote/DTPO/CO: | Q81954413 |
| Prepared by: | Louis J Domenico III | | Version Number: | 35.20 |



Hunter Truck Sales and Service H546
1328 Golden Slipper Road

Pocono Township
112 Township Dr

Bartonsville, Pennsylvania United States 18321
Phone: (570) 688-2400
Fax:
Email: Idomenico@poconopeterbilt.com

Tannersville, Pennsylvania United States 18372
Phone: (570) 888-4344
Fax:
Contact Email:
Prepared for:

Horizontal Dimensions

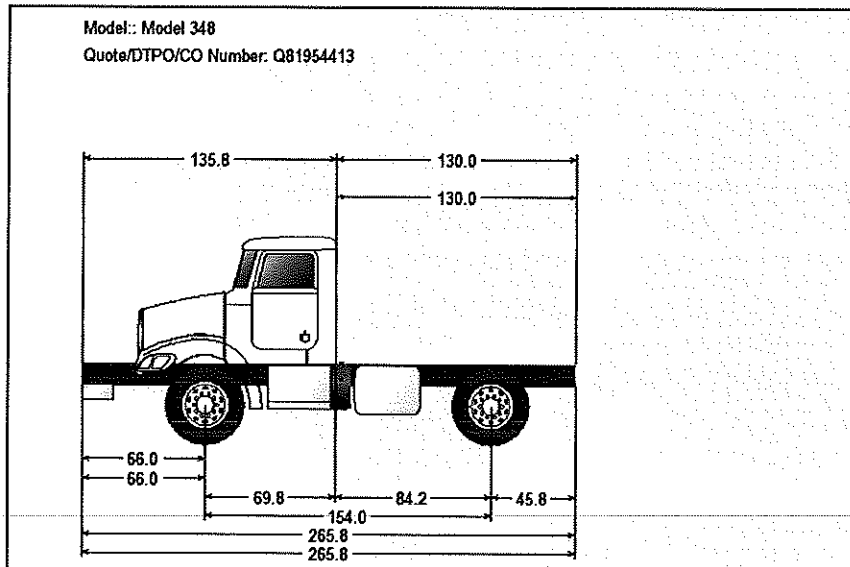

Unpublished options may require review/approval.
Dimensional and performance data for unpublished options may vary from that displayed in PROSPECTOR.

Printed: 03/08/2018 3:42:23 PM
Effective Date: Jul 1, 2017
Prepared by: Louis J Domenico III

Complete

Model Number: Model 348
Quote/DTPO/CO: Q81954413
Version Number: 35.20



Hunter Truck Sales and Service H546
1328 Golden Slipper Road

Pocono Township
112 Township Dr

Bartonsville, Pennsylvania United States 18321
Phone: (570) 688-2400
Fax:
Email: Idomenico@poconopeterbilt.com

Tannersville, Pennsylvania United States 18372
Phone: (570) 888-4344
Fax:
Contact Email:
Prepared for:

Weight Distribution

Weight Distribution

Actual performance of a specific unit can be affected by your operating conditions. The performance calculations should only be used as a guideline.

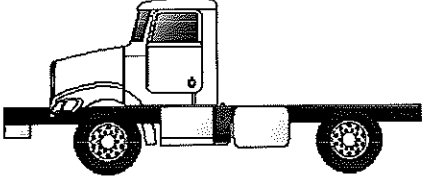
| Truck Spec | Auxiliary Payload |
|--|-------------------|
| Model: Model 348 Quote/DTPO/CO Number: Q44454013 | |
|  | |

Recommended Payload Center of Gravity to achieve specified ground loads; measured from centerline of drive axle(s): 47 in. from the centerline of the drive axle(s).

| Weight (lbs) | Front | Rear | Total |
|---------------------|-------|-------|-------|
| Chassis | 7693 | 4519 | 12112 |
| Tools/Driver | 265 | 110 | 375 |
| Fuel & DEF | 186 | 420 | 606 |
| Max Payload | 7956 | 17351 | 25307 |
| Auxiliary Payload | 0 | 0 | 0 |
| Total | 16000 | 23000 | 39000 |
| Specify Ground Load | 16000 | 23000 | |

Unpublished options may require review/approval.
Dimensional and performance data for unpublished options may vary from that displayed in PROSPECTOR.

Printed: 03/08/2018 3:44:11 PM
Effective Date: Jul 1, 2017
Prepared by: Louis J Domenico III

Complete

Model Number: Model 348
Quote/DTPO/CO: Q44454013
Version Number: 35.20



Hunter Truck Sales and Service H546
1328 Golden Slipper Road

Pocono Township
112 Township Dr

Bartonsville, Pennsylvania United States 18321
Phone: (570) 688-2400
Fax:
Email: Idomenico@poconopeterbilt.com

Tannersville, Pennsylvania United States 18372
Phone: (570) 888-4344
Fax:
Contact Email:
Prepared for:

Fuel Tanks

Summary
 Right Left

Location
Under Cab
Back Of Cab 1
Back Of Cab 2
Between Rails
ClearFrame
Def Tank

Type

Material

Diameter

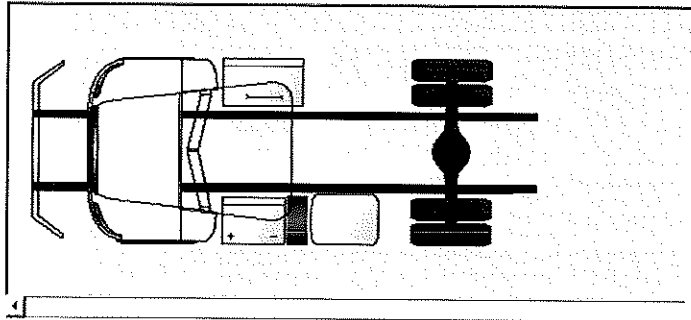

Top View Right Side Available Space: 51.05 in. Current Wheelbase Space: 154
 Side View Left Side Available Space: 10.75 in. Required Wheelbase Space: 144

| Position | Description | Price | Weight |
|-------------|--|-------|--------|
| RH Under | Aftreatment RH U/C ALUMINUM Non-Slip Cab Entry | 0 | 0 |
| LH Under | Aluminum Battery Box LH Under Cab, Non-Slip Step | 178 | -55 |
| LH BOC1 | 26 in Aluminum 70 Gallon Fuel Tank LH BOC | 117 | 119 |
| LH Def Tank | DEF Tank Small | 0 | 0 |

Unpublished options may require review/approval.
Dimensional and performance data for unpublished options may vary from that displayed in PROSPECTOR.

Printed: 03/08/2018 3:43:57 PM **Complete** Model Number: Model 348
Effective Date: Jul 1, 2017 Quote/DTPO/CO: Q44354484
Prepared by: Louis J Domenico III Version Number: 35.20



Hunter Truck Sales and Service H546
1328 Golden Slipper Road

Pocono Township
112 Township Dr

Bartonsville, Pennsylvania United States 18321
Phone: (570) 688-2400
Fax:
Email: ldomenico@poconopeterbilt.com

Tannersville, Pennsylvania United States 18372
Phone: (570) 888-4344
Fax:
Contact Email:
Prepared for:

Vehicle Weight Rating

Front Axle

| Component | Code | Description | Weight (lbs) |
|---------------------|---------|--|--------------|
| Axle | 1011360 | Dana Spicer D2000F 20,000 lb, 3.5 in. Drop | 20,000 |
| Springs | 1112160 | Taper Leaf Springs, Shocks 16,000 lb | 16,000 |
| Power Steering | 1233110 | Power Steering TRW THP60 Dual | 20,000 |
| Hubs, Drums, Brakes | 1354845 | PHP10 Iron PreSet Hubs | 22,000 |
| Tires | 5032300 | FF: GY 18ply 315/80R22.5 G291 | 16,540 |
| Wheels | 5220520 | FF: Alcoa 89U637 22.5X9.00 Clean Buff Finish | 20,000 |

Requested Front Axle Rating is 16,000

Front Axle Weight Rating is limited to 16,000 #

Rear Axle

| Component | Code | Description | Weight (lbs) |
|---------------------|---------|--|--------------|
| Axle | 1513180 | Dana Spicer S23-190 23,000 lb | 23,000 |
| Hubs, Drums, Brakes | 1616370 | PHP10 Iron PreSet Hubs | 67,000 |
| Parking Brakes | 1631310 | Standard Stroke Parking Brakes | 70,000 |
| Suspension | 1811210 | Peterbilt Air Trac 23,000 lb Light Weight | 23,000 |
| Tires | 5133390 | RR: GY 16ply 11R22.5 G182 RSD GHG | 24,020 |
| Wheels | 5321740 | RR: Alcoa 883677 22.5X8.25 Clean Buff Finish | 29,600 |

Requested Rear Axle Rating is 23,000

The Rear Axle Weight Rating is limited to 23,000 #

Tire rating is based on tire psi. Tire psi is based on the max wheel psi. The tire psi cannot exceed the wheel max psi.

Unpublished options may require review/approval.
Dimensional and performance data for unpublished options may vary from that displayed in PROSPECTOR.

| | | | | |
|-----------------|-----------------------|-----------------|-----------------|-----------|
| Printed: | 03/08/2018 3:44:06 PM | Complete | Model Number: | Model 348 |
| Effective Date: | Jul 1, 2017 | | Quote/DTPO/CO: | Q44454013 |
| Prepared by: | Louis J Domenico III | | Version Number: | 35.20 |



Hunter Truck Sales and Service H546
1328 Golden Slipper Road

Pocono Township
112 Township Dr

Bartonsville, Pennsylvania United States 18321

Phone: (570) 688-2400

Fax:

Email: Idomenico@poconopeterbilt.com

Tannersville, Pennsylvania United States 18372

Phone: (570) 888-4344

Fax:

Contact Email:

Prepared for:

Cruise Performance

Configuration: Model 348 / Full Truck GCW: 39000

Quote/DTPO/CO Number: Q81954413

Aerodynamic Aids: None

Engine: 2074406 PACCAR PX-9 350@2000 GOV@2200 1150@1400
Transmission: 4052110 Allison 3000 RDS-P Transmission, Gen 5
Rear Axle: 1513180 Dana Spicer S23-190 23,000 lb 5.57 Ratio
Rear Tire: 5133390 RR: GY 16ply 11R22.5 G182 RSD GHG Revs/Mile: 499

Operating Conditions: 0.7% Rolling Resistance, Engine Fan: Off

Startability:

| Transmission Ratio | Maximum Starting Grade (%) |
|--------------------|----------------------------|
| 3.49 | 14.10 |
| 1.86 | 7.10 |

| | 1200 | 1300 | 1400 | 1500 | 1600 | 1700 | 1800 | 1900 | 2000 | 2100 | 2200 |
|---------------|------|------|------|------|------|------|------|------|------|------|------|
| Engine RPM: | 1200 | 1300 | 1400 | 1500 | 1600 | 1700 | 1800 | 1900 | 2000 | 2100 | 2200 |
| Gross Torque: | 1025 | 1088 | 1150 | 1142 | 1125 | 1066 | 1007 | 954 | 920 | 850 | 765 |
| Net Torque: | 929 | 990 | 1049 | 1043 | 1028 | 974 | 920 | 872 | 841 | 777 | 698 |
| Net HP: | 212 | 245 | 280 | 298 | 313 | 315 | 315 | 315 | 320 | 311 | 293 |

| Gear Ratios: TRN:(1) | 3.49 | RAX:(1) | 5.57 | | | | | | | | |
|----------------------|------|---------|------|------|------|------|------|------|------|------|------|
| Speed (MPH): | 7.4 | 8.0 | 8.7 | 9.3 | 9.9 | 10.5 | 11.1 | 11.8 | 12.4 | 13.0 | 13.6 |
| Grade (%): | 27.8 | 29.8 | 31.8 | 31.6 | 31.1 | 29.3 | 27.5 | 25.9 | 24.9 | 22.9 | 20.4 |

| Gear Ratios: TRN:(2) | 1.86 | RAX:(1) | 5.57 | | | | | | | | |
|----------------------|------|---------|------|------|------|------|------|------|------|------|------|
| Speed (MPH): | 13.9 | 15.1 | 16.2 | 17.4 | 18.6 | 19.7 | 20.9 | 22.1 | 23.2 | 24.4 | 25.5 |
| Grade (%): | 14.1 | 15.1 | 16.0 | 15.9 | 15.7 | 14.8 | 14.0 | 13.2 | 12.7 | 11.6 | 10.4 |

| Gear Ratios: TRN:(3) | 1.41 | RAX:(1) | 5.57 | | | | | | | | |
|----------------------|------|---------|------|------|------|------|------|------|------|------|------|
| Speed (MPH): | 18.4 | 19.9 | 21.4 | 23.0 | 24.5 | 26.0 | 27.6 | 29.1 | 30.6 | 32.2 | 33.7 |
| Grade (%): | 10.5 | 11.2 | 11.9 | 11.9 | 11.7 | 11.0 | 10.4 | 9.8 | 9.4 | 8.6 | 7.7 |

| Gear Ratios: TRN:(4) | 1.00 | RAX:(1) | 5.57 | | | | | | | | |
|----------------------|------|---------|------|------|------|------|------|------|------|------|------|
| Speed (MPH): | 25.9 | 28.1 | 30.2 | 32.4 | 34.5 | 36.7 | 38.9 | 41.0 | 43.2 | 45.3 | 47.5 |
| Grade (%): | 7.2 | 7.7 | 8.2 | 8.2 | 8.0 | 7.6 | 7.1 | 6.7 | 6.4 | 5.9 | 5.2 |

Unpublished options may require review/approval.
Dimensional and performance data for unpublished options may vary from that displayed in PROSPECTOR.

Printed: 03/08/2018 3:42:31 PM
Effective Date: Jul 1, 2017
Prepared by: Louis J Domenico III

Complete

Model Number: Model 348
Quote/DTPO/CO: Q81954413
Version Number: 35.20



Gear Ratios: TRN:(5) 0.75 RAX:(1) 5.57
Speed (MPH): 34.5 37.4 40.3 43.2 46.1 48.9 51.8 54.7 57.6 60.4 63.3
Grade (%): 5.2 5.6 6.0 5.9 5.9 5.5 5.2 4.9 4.7 4.2 3.7

Gear Ratios: TRN:(6) 0.65 RAX:(1) 5.57
Speed (MPH): 39.9 43.2 46.5 49.8 53.1 56.5 59.8 63.1 66.4 69.7 73.1
Grade (%): 4.4 4.8 5.1 5.1 5.0 4.7 4.4 4.1 3.9 3.6 3.2

Engine RPM: 1200 1300 1400 1500 1600 1700 1800 1900 2000 2100 2200
Gross Torque: 1025 1088 1150 1142 1125 1066 1007 954 920 850 765
Net Torque: 929 990 1049 1043 1028 974 920 872 841 777 698
Net HP: 212 245 280 298 313 315 315 315 320 311 293

Unpublished options may require review/approval.
Dimensional and performance data for unpublished options may vary from that displayed in PROSPECTOR.

| | | | | |
|-----------------|-----------------------|-----------------|-----------------|-----------|
| Printed: | 03/08/2018 3:42:31 PM | Complete | Model Number: | Model 348 |
| Effective Date: | Jul 1, 2017 | | Quote/DTPO/CO: | Q81954413 |
| Prepared by: | Louis J Domenico III | | Version Number: | 35.20 |

RECEIVED

MAR 28 2018

E. M. KUTZ, INC.
2456 Morgantown Road
Reading, PA 19607
610-775-3528/610-775-4848-Fax

POCONO TOWNSHIP

Date: March 28, 2018

PROPOSAL

Pat Briegel
Pocono Township
Cc: Hunter-Keystone Peterbilt

Sales Agent: Matt Lynott/Dale Smith

DESCRIPTION

Furnish and install the following per COSTARS 025-053

Chassis to arrive with front frame extension, Allison series 3000 transmission with PTO access, PTO switch and factory upfitter switches, 84" clear frame cab to axle on Peterbilt chassis. Hydraulic system requires a minimum of 36" clear frame space behind cab for valve/tank enclosure.

Body

Godwin/R&S AG Series Aluminum Dump Body

10 1/2' x 86" Interior width x 30" sides x 40" tailgate
3/16" aluminum sides with vertical side braces only
Extruded aluminum top rails and bottom dirt shedder rails
Aluminum grip strut walkway between vertical uprights, full length on each side
HD 1/4" 5454 aluminum floor material
3/16" 3/4 cab shield with built in wind deflector
1/4" aluminum (6) panel air operated - two way swing tailgate
5" aluminum I-beam longsills with rubber cushion strip
~~4" boxed aluminum extruded crossmembers on 12" centers~~
Champion/R&S 850LMDA-FF low mount hoist assembly

Hydraulics

CS24 PTO/P50 gear pump
Bosch Rexroth 5 spool valve in Stainless steel enclosure
25 gallon Aluminum hydraulic tank with sight glass
Compu Spread model 520 spreader controller
CS 106 HOIST AND PLOW CONTROLLER DUAL JOYSTICK
All necessary hoses and fittings to complete circuit

Snow Plow

Gledhill Model 11HSBPR2 snow plow
11' x 42" high moldboard
4" X 20" D/A angle cylinders
Heavy duty mushroom shoes
Level lift
Blade guides
3/4 X 6" X 11' carbide cutting edge on plow

Plow Hitch

Gledhill Model FFLP front frame hitch
4 x 10" D/A lift cylinder
QCP connection for plow and hitch

(Continued)

Pocono Township Price Quote

March 28, 2018

Page - 2

Description: (continued)

Spreader

Swenson Model SAG stainless steel spreader
Gear box driven auger
Poly spinner
Dump body filler plates

Lights

Snow plow lights mounted on fenders
Four (4) oval LED amber lights mounted in cab shield
One (1) oval LED amber light mounted in each rear post
LED stop/tail/back-up lights in rear posts
LED spreader work light

Miscellaneous

Aluminum tool box, frame mounted, per allowed space
Aero 575 automatic tarp system with double arms
Pintle plate with BP200 pintle
Welded/fabricated and plow hitch painted black
Exterior of body to be hand cleaned bare aluminum finish

Price Per Unit - \$64,661.00

Pricing reflects a cash or check discount. Credit card purchases will incur a 4% surcharge to be added to order total.

All prices quoted do not include applicable taxes unless otherwise noted.

Customer Approval By: _____
Name Title Date

Purchase Order Number: _____

F.O.B. E. M. Kutz, Inc.

Terms: Net due upon completion.

Delivery: Please allow 45 to 90 days to complete unit after equipment and chassis arrival.

Dump body components are currently at 12-14 weeks out

Paint - Due to the variety of colors currently being provided by chassis manufacturers, E. M. Kutz, Inc. can no longer guarantee a 100% match.

All claims are contingent upon strikes, accidents and other caused beyond our control, including similar contingencies to our shippers or vendors and relative to the subject matter hereof. Clerical errors are subject to correction.

Note: All chassis to arrive with sufficient material to mount and install fuel tank or tank filler necks. Any additional material or labor needed for this there will be an upcharge. Also any rerouting of exhaust needed to mount P.T.O. or pumps there will be an upcharge.

Price Valid for 30 Days From Above Date



Hunter Truck Sales and Service H546
1328 Golden Slipper Road

Pocono Township
112 Township Dr

Bartonsville, Pennsylvania United States 18321
Phone: (570) 688-2400
Fax:
Email:

Tannersville, Pennsylvania United States 18372
Phone: (570) 888-4344
Fax:
Contact Email:
Prepared for: Donna Azure

Customer Quote

Equipment

| | |
|-------------------------------------|-----------|
| Quantity Ordered: | 1 |
| Truck Price: | \$221,859 |
| Dealer Options: | \$0 |
| Equipment List Price: | \$221,859 |
| Surcharges Not Subject to Discount: | \$0 |
| Options Not Subject to Discount: | \$0 |
| Factory Freight Cost: | \$2,325 |

Total Equipment Price: \$224,184

NET Sale Price: \$127,706

Miscellaneous

| | | |
|-------------------------------|-----|-----|
| FET Tire Credit: | \$0 | |
| Net Chassis FET: | | \$0 |
| State Tax: | | \$0 |
| Body/Trailer/Accessories FET: | | \$0 |
| Fees: | | \$0 |
| Other: | | \$0 |

Quotation Total: \$127,706

Unpublished options may require review/approval.
Dimensional and performance data for unpublished options may vary from that displayed in PROSPECTOR.

| | | | | |
|-----------------|-----------------------|-----------------|-----------------|-----------|
| Printed: | 04/13/2018 8:09:10 AM | Complete | Model Number: | Model 365 |
| Effective Date: | Jan 1, 2018 | | Quote/DTPO/CO: | Q30254245 |
| Prepared by: | ID: Idomenico | | Version Number: | 36.21 |



Hunter Truck Sales and Service H546
1328 Golden Slipper Road

Pocono Township
112 Township Dr

Bartonsville, Pennsylvania United States 18321
Phone: (570) 688-2400
Fax:
Email:

Tannersville, Pennsylvania United States 18372
Phone: (570) 888-4344
Fax:
Contact Email:
Prepared for: Donna Azure

Vehicle Summary

| Unit | | Chassis | |
|-------------------------|-----------------|----------------------------|-------|
| Model: | Model 365 | Fr Axle Load (lbs): | 20000 |
| Type: | Full Truck | Rr Axle Load (lbs) | 46000 |
| Description: | 2018 Pricing | G.C.W. (lbs): | 66000 |
| Application | | Road Conditions: | |
| Intended Serv.: | Snowplow | Class A (Highway) | 100 |
| Commodity: | Other Commodity | Class B (Hwy/Mtn) | 0 |
| Body | | Class C (Off-Hwy) | 0 |
| Type: | End Dump | Class D (Off-Road) | 0 |
| Length (ft): | 14 | Maximum Grade: | 6 |
| Height (ft): | 12.0 | Wheelbase (in): | 191 |
| Max Laden Weight (lbs): | 4600 | Overhang (in): | 60 |
| Trailer | | Fr Axle to BOC (in): | 68.9 |
| No. of Trailer Axles: | 0 | Cab to Axle (in): | 122.1 |
| Type: | | Cab to EOF (in): | 182.1 |
| Length (ft): | 0 | Overall Comb. Length (in): | 320 |
| Height (ft): | 0.0 | Special Req. | |
| Kingpin Inset (in): | 0 | United States Registry | |
| Corner Radius (in): | 0 | | |
| Restrictions | | | |
| Length (ft): | 65 | | |
| Width (in): | 102 | | |
| Height (ft): | 13.5 | | |

Approved by: _____

Date: _____

Note: All sales are F.O.B. designated plant of manufacture.

| | |
|-----------------------------|--|
| PACCAR FINANCIAL | Ask your dealer for a quote today, or visit our website @ www.paccarfinancial.com . |
| | PACCAR Financial offers innovative finance, lease and insurance programs customized to meet your needs. |

Unpublished options may require review/approval.
Dimensional and performance data for unpublished options may vary from that displayed in PROSPECTOR.

| | | | | |
|-----------------|------------------------|-----------------|-----------------|-----------|
| Printed: | 03/09/2018 10:02:18 AM | Complete | Model Number: | Model 365 |
| Effective Date: | Jan 1, 2018 | | Quote/DTPO/CO: | Q55854571 |
| Prepared by: | ID: Idomenico | | Version Number: | 36.10 |



Hunter Truck Sales and Service H546
1328 Golden Slipper Road

Pocono Township
112 Township Dr

Bartonsville, Pennsylvania United States 18321
Phone: (570) 688-2400
Fax:
Email:

Tannersville, Pennsylvania United States 18372
Phone: (570) 888-4344
Fax:
Contact Email:
Prepared for: Donna Azure

| | Description | Weight |
|-----------------------------------|--|--------|
| Base Model | | |
| | Model 365 | 14,940 |
| | Other Commodity | 0 |
| | Snowplow Truck which is configured for mounting a snowplow to the front. May also have dump or other body. | 0 |
| | End Dump | 0 |
| | United States Registry | 0 |
| Configuration | | |
| | Not Applicable Secondary Manufacturer | 0 |
| Frame & Equipment | | |
| | 10-11/16in Steel Rails to 286in-325in 1/2in Rail Thickness; 10.6875 x 3.5 x 0.5 Dimension. 2,683,000 lbs. RBM; Yield Strength: 120,000 psi. Section Modulus: 22.35 cubic inches. Weight: 2.35 lbs/inch pair | 730 |
| | Heavy-Duty Iron Front Spring Brackets Forward and Rear | 35 |
| | 22.4in Rail Extension for Snowplow w/out Adapter Includes Stationary Grille | 106 |
| | EOF Square without Xnbr For use with body builder installed crossmember. | -64 |
| | Omit Rear Mudflaps and Hangers | -25 |
| Front Axle & Equipment | | |
| | Dana Spicer D2000F 20,000 lb, 3.5 in. Drop Factory front axle alignment to improve handling & reduce tire wear. Zerk fittings on tie rod ends, king pins, & draglink ball joints for ease of maintenance & help extend service life of components. Cognis EMGARD® FE 75W-90 synthetic axle lube provides over 1% fuel economy improvement. Reduces wear & extends maintenance intervals, resulting in increased uptime. Provides improved fluid flow to protect components in extreme cold conditions & withstand the stress from high temperatures, extending component life. | 137 |
| | Taper Leaf Springs, Shocks 20,000 lb Standard with Heavy Resistance Shocks. | 132 |

Unpublished options may require review/approval.
Dimensional and performance data for unpublished options may vary from that displayed in PROSPECTOR.

| | | | | |
|-----------------|------------------------|-----------------|-----------------|-----------|
| Printed: | 03/09/2018 10:02:18 AM | Complete | Model Number: | Model 365 |
| Effective Date: | Jan 1, 2018 | | Quote/DTPO/CO: | Q55854571 |
| Prepared by: | ID: Idomenico | | Version Number: | 36.10 |



| Description | Weight |
|---|--------|
| Power Steering TRW TAS65 Dual For use with 16,000 to 20,000 lb. axle ratings. Glidekote splines on steering shaft extend service life of components. | 58 |
| Power Steering Reservoir Frame Mounted w/Cooler | 2 |
| PHP10 Iron PreSet PLUS Hubs | -113 |
| Greasable Front Spring Pins | 0 |
| Bendix Air Cam Front Drum Brakes 16.5x6 Includes automatic slack adjusters & outboard mounted brake drums. | 0 |
| Gusseted Cam Brackets, Steer Axle | 0 |

Rear Axle & Equipment

| | |
|---|-----|
| Dana Spicer D46-170 46,000 lb Interaxle diff lock air rocker occupies space of one gauge. Laser factory axle alignment to improve handling & reduce tire wear. Magnetic rear axle oil drain plug captures & holds any metal fragments in drive axle lube to extend service life. Parking brakes on all drive axles for optimal performance. Cognis EMGARD® FE 75W-90 synthetic axle lube provides over 1% fuel economy improvement. Reduces wear & extends maintenance intervals, resulting in increased uptime. Provides improved fluid flow to protect components in extreme cold conditions & withstand the stress from high temperatures, extending component life. | 550 |
| PHP10 Iron PreSet PLUS Hubs | 0 |
| Long Stroke Parking Brakes, Drive Axle(s) | 0 |
| Dust Shields For Cam Brakes, Drive Axle(s) | 0 |
| Diff Lock Both Axles (Air Rocker Switch occupies the space of one gauge) | 60 |
| Separate Dash Controls, Cont Trac Full Lock Dana Spicer or Meritor - Tandem or TriDrive Axles (Air Rocker Switch occupies the space of two gauges for tandem axle and three gauges for tri-drive axle) | 2 |
| Gusseted Cam Brackets, Drive Axle(s) | 2 |
| SBM Valve Full trucks require a spring brake modulation (SBM) system for emergency braking application. This system requires an SBM valve and a relay valve with spring brakes on the rear axles. The SBM valve allows the foot valve to operate the rear axle spring brakes if a failure exists in the rear air system. | 0 |
| Stability System Not Selected or Not Available | 0 |
| Anti-Lock Braking System (ABS) 6S6M ABS-6. Includes air braking system. | 0 |

Unpublished options may require review/approval.
Dimensional and performance data for unpublished options may vary from that displayed in PROSPECTOR.

| | | | | |
|-----------------|------------------------|-----------------|-----------------|-----------|
| Printed: | 03/09/2018 10:02:18 AM | Complete | Model Number: | Model 365 |
| Effective Date: | Jan 1, 2018 | | Quote/DTPO/CO: | Q55854571 |
| Prepared by: | ID: Idomenico | | Version Number: | 36.10 |



| Description | Weight |
|---|--------|
| Synthetic Axle Lubricant All Axles Peterbilt heavy duty models include Fuel Efficient Cognis EMGARD FE75W-90 which provides customers performance advantages over current synthetic lubricants with reduced gear wear and extended maintenance intervals, resulting in increased uptime. In addition, the lubricant provides improved fluid flow to protect gears in extreme cold conditions and withstand the stress from high temperatures, extending component life. | 0 |
| Bendix Air Cam Rear Drum Brakes 16.5x7 Includes Automatic Slack Adjusters & Outboard Mounted Brake Drums. | 0 |
| Ratio 4.30 Rear Axle | 0 |
| Peterbilt Air Trac 46,000 lbs, 54in Axle Spacing Light Weight | 291 |
| Air Springs, Internal Bumpers Air Trac / Air Leaf suspensions | 0 |
| Dash Mtd Dump Switch With Indicator Light For suspension | 2 |

Engine & Equipment

| | |
|--|------|
| PACCAR MX-11 400@1600 GV@2200 1450@900 (2017 EMISSIONS) | -400 |
| N20690 N162 75...Maximum Accelerator Pedal Vehicle Speed | |
| N20700 N006 75...Max Cruise Speed | |
| N20710 N052 650...Idle Target | |
| N20740 N015 NO...Enable MX Retarder in Neutral | |
| N20750 N019 0....Delay in Engine Brake Activation w/ Brake Pedal Depressed | |
| N20760 N014 2....Auto Retard Vehicle Speed Offset | |
| N20770 N013 4....Downhill Speed Limiter Vehicle Speed Offset | |
| N20780 N001 16...Minimum Speed to Turn Cruise Control Off | |
| N20790 N003 19...Minimum Cruise Control Speed | |
| N20800 N002 19...Min Speed to Automatically Turn Cruise Control On | |
| N20830 N039 OFF..Allow Multi-Torque Only When Cruise is Active | |
| N20840 N187 5....Timer Setting Non-PTO Mode w/ Park Brake Set | |
| N20850 N188 5....Timer Setting Non-PTO Mode w/o Park Brake Set | |
| N20860 N185 40...Low Ambient Temperature Override | |
| N20870 N184 80...High Ambient Temperature Override | |
| N20900 N186 5....Timer Setting When in PTO Mode | |
| N20910 N190 YES..Reset EIST Timer Based on Engine Load | |
| N20930 N071 ON...FIC Enable/Disable | |
| N20940 N072 1900.Maximum Fast Idle Control Engine Speed | |
| N20990 N078 ON...PTO Mode Disabled w/ Clutch Pedal Depressed | |
| N21000 N101 ON...PTO Mode Disabled w/ Service Brake Depressed | |
| N21010 N079 ON...PTO Mode Enable Only w/ Parking Brake Set | |
| N21020 N080 5....PTO Vehicle Speed Limit | |
| N21030 N089 ON...PTO Mode Enable Only w/ Transmission Neutral | |
| N21100 N087 1000.RPM Set Point | |
| N21110 N086 2000.Maximum Engine Speed During PTO Operation | |
| N21160 N110 0....Enable Set Point w/ Set/Accel Switch Bump | |
| N21170 N191 NO...Override EIST Timer Based on Engine Load | |
| N21190 N193 0....Expiration Distance | |

Unpublished options may require review/approval.
Dimensional and performance data for unpublished options may vary from that displayed in PROSPECTOR.

| | | | | |
|-----------------|------------------------|-----------------|-----------------|-----------|
| Printed: | 03/09/2018 10:02:18 AM | Complete | Model Number: | Model 365 |
| Effective Date: | Jan 1, 2018 | | Quote/DTPO/CO: | Q55854571 |
| Prepared by: | ID: Idomenico | | Version Number: | 36.10 |



| Description | Weight |
|--|----------|
| N21230 N197 YES..Enable Accelerator Pedal Reset | |
| N21240 N198 YES..Enable Service Brake Reset | |
| N21250 N199 YES..Enable Clutch Pedal Reset | |
| N21260 N200 YES..Allow EIST Timer Overrides in PTO Mode | |
| N21280 N163 0....Maximum Cycle Distance | |
| N21300 N169 0....Expiration Distance | |
| N21310 N170 75...Standard Maximum Speed Limit [LSL] | |
| N21320 N106 650..Minimum Engine Speed During PTO Operation | |
| N21640 N179 YES..Enable Park Brake Reset | |
| N21650 N173 0....Reserve Speed Offset | |
| N21670 N164 252..Reserve Speed Function Reset Distance | |
| N21900 N073 0....Cab Accel Pedal Type in PTO Mode | |
| N21910 N182 30...Coolant Temperature Override | |
| N21920 N219 0....Offset mode | |
| N21930 N224 2....Maximum Vehicle Speed Bonus | |
| N21940 N227 -2...Maximum Vehicle Speed Penalty | |
| N21950 N246 4....Minimum Vehicle Speed for DSA Activation | |
| N21960 N247 1....Lowest Gear that DSA will be active | |
| N21970 N248 6....Highest Gear that DSA will be active | |
| N21980 N076 2000.Max Accelerator Controlled Eng Spd During PTO Operation | |
| N21990 N307 OFF..Cab Accelerator Active in Remote PTO Mode | |
| Engine Idle Shutdown Timer Enabled | 0 |
| Enable EIST Ambient Temp Override | 0 |
| Eff EIST NA Expiration Miles | 0 |
| Enable Reserve Speed Drive Cycle Limit | 0 |
| Effective VSL Setting NA | 0 |
| Typical Operating Speed 60 MPH | 0 |
| MX Retarder State Cruise Control On (Manual Mode Engine Parameter) | 0 |
| Powertrain Optimized for Balance | 0 |
| Best analysis for vehicles where service includes frequent start and stop cycles. | |
| PTO Stationary-Cab Station Switches and Accelerator | 0 |
| Enable MX Retarder Auto Retard (Engine Parameter) | 0 |
| Engine Monitoring Protection - Derate | 0 |
| (PACCAR MX) A warning is provided in the A-Panel display when DPF regeneration is required. Continued operation without regeneration will initiate automate derating of the engine's power and can result in damage to the engine. | |
| CARB Engine Idling Compliance | 0 |
| PACCAR PX-7, PX-9 and MX, Cummins ISL, ISM and ISX diesel engines will include the required factory installed serialized sticker on the drivers door to identify them as meeting the NOx idling standard. | |
| PACCAR 160 Amp Alternator, Brushed | 0 |

Unpublished options may require review/approval.
Dimensional and performance data for unpublished options may vary from that displayed in PROSPECTOR.

| | | | | |
|-----------------|------------------------|-----------------|-----------------|-----------|
| Printed: | 03/09/2018 10:02:18 AM | Complete | Model Number: | Model 365 |
| Effective Date: | Jan 1, 2018 | | Quote/DTPO/CO: | Q55854571 |
| Prepared by: | ID: Idomenico | | Version Number: | 36.10 |



| Description | Weight |
|--|--------|
| Immersion Type Block Heater 110-120V Standard location is center left hand under cab and includes a weather-proof cover that protects the receptacle. This pre-heater keeps the coolant in the engine block from freezing when the engine is not running. | 0 |
| PACCAR 12V Starter | 0 |
| 3 PACCAR Premium 12V Dual Purpose Batt 2190 CCA Threaded stud type terminal. Stranded copper battery cables are double aught (00) or larger to reduce resistance. | 0 |
| Kissling Battery Disconnect Switch Mounted on battery box | 3 |
| 2-Speed Fan Clutch For Frequent Start/Stops | 0 |
| Wabco 25.9 CFM Air Compressor, MX only | -17 |
| Compression Brake, MX | 0 |
| PACCAR Fuel/Water Separator Standard Service Interval | 0 |
| No Fluid Heat Option for Fuel Filter | 0 |
| 12V Heat for Fuel Filter | 0 |
| High Efficiency Cooling System Cooling module is a combination of steel and aluminum components, with aluminum connections to maximize performance and cooling capability. Silicone radiator & heater hoses enhance value, durability, & reliability. Constant tension band clamps reduce leaks. ClimaTech extended life coolant extends maintenance intervals which reduces maintenance costs. Anti-freeze effective to -30 degrees F helps protect the engine. Low coolant level sensor warns of low coolant condition to prevent engine damage. Radiator Size by Model: 587: 1330 sq in, 579/367 FEPTO 1325 sq in, 567/365/367: 1440 sq in, 384/386: 1301 sq in, 365 FEPTO: 1184 sq in, 389/367 HH: 1669 sq in, 348: 1000 sq in, 320: 1242 sq in. | 0 |
| (1) Air Cleaner Firewall Mounted Molded rubber air intake connections with lined stainless steel clamps seal to prevent contaminants in air intake. | 0 |
| Exhaust Single RH Side Of Cab DPF/SCR RH Under Cab (2017). | 0 |
| Curved Tip Standpipe(s) | 0 |
| 36in Ht, 5in Dia Chrome, Clear Coat Standpipe(s) | 4 |

Transmission & Equipment

Unpublished options may require review/approval.
Dimensional and performance data for unpublished options may vary from that displayed in PROSPECTOR.

| | | | | |
|-----------------|------------------------|-----------------|-----------------|-----------|
| Printed: | 03/09/2018 10:02:18 AM | Complete | Model Number: | Model 365 |
| Effective Date: | Jan 1, 2018 | | Quote/DTPO/CO: | Q55854571 |
| Prepared by: | ID: Idomenico | | Version Number: | 36.10 |



| Description | Weight |
|--|--------|
| Allison 4500 RDS-P Transmission, Gen 5 Rugged Duty Series. Includes Rear Transmission Support except on MX engines, TranSynd Transmission Fluid, and Water Oil Heat Exchange. Also includes features that monitor the transmission fluid, filter and clutch condition. Will display percent life remaining for the transmission fluid, filter and clutches on the shift selector. This information may be displayed using the Mode and Up and Down buttons. A wrench icon will also be included to indicate when the transmission fluid, filter or clutches need servicing. (Suited for vehicles operating on/off highway and/or requiring PTO operation) Forward Ratios: 1st-4.70, 2nd-2.21, 3rd-1.53, 4th-1.00, 5th-0.76, 6th-0.67 / Reverse Ratios: DR-(5.55) | 200 |
| SPL250 Lite HT Driveline, 1 Midship Bearing | 140 |
| SPL170 XL Driveline Interaxle For tandem rear axles | 0 |
| (1) Dash Mounted Single Acting Air PTO Control Standard with PTO engaged indicator light on Class 8 units. Occupies the space of one gauge. Specing PTO switch does not ensure the PTO will fit. | 0 |
| Allison FuelSense Not Desired | 0 |
| Auto Neutral Activates With Parking Brake | 0 |
| Allison 6-Speed Configuration, Wide Ratio Gears Allison 4500 Transmission Only | 0 |
| Dash Mounted Push Button Shifter Available with Allison Transmissions. | 0 |
| Air & Trailer Equipment | |
| Bendix AD-IS EP Air Dryer with Heater And Coalescing Filter; Extended Purge | 6 |
| Pull Cords All Air Tanks | 0 |
| Nylon Chassis Hose | 0 |
| Steel Painted Air Tanks All air tanks are steel with painted finish except when Code 4543330 Polish Aluminum Air Tanks is also selected (then exposed air tanks outside the frame rails will be polished aluminum). Peterbilt will determine the optimal size and location of required air tanks. Narratives requesting a specific air tank size or location will not be accepted for factory installation. See ECAT to determine number or location of air tanks installed. | 0 |
| Body Connections 5ft BOC Junction Box contains light and power circuits for Body Connections located 5ft from BOC. | 6 |
| Trailer Hand Valve With Column-Mounted Controls | 0 |
| A&E Conn EOF w/7-way Socket (w/Conn EOF Strapped to the rail) | 15 |

Unpublished options may require review/approval.
 Dimensional and performance data for unpublished options may vary from that displayed in PROSPECTOR.

| | | | | |
|-----------------|------------------------|-----------------|-----------------|-----------|
| Printed: | 03/09/2018 10:02:18 AM | Complete | Model Number: | Model 365 |
| Effective Date: | Jan 1, 2018 | | Quote/DTPO/CO: | Q55854571 |
| Prepared by: | ID: Idomenico | | Version Number: | 36.10 |



| | Description | Weight |
|---------------------------------|---|--------|
| Tires & Wheels | | |
| | FF: GY 20Ply 315/80R22.5 Endurance WHA | 62 |
| | RR: GY 14ply 11R22.5 G182 RSD | 160 |
| | Diameter = 42.1 inches; SLR = 19.6 inches | |
| | Code-rear Tire Qty 08 | 0 |
| | FF: Alcoa 89U647 22.5X9.00 Clean Buff Finish | -20 |
| | Aluminum, Ultra ONE wheels with MagnaForce alloy. | |
| | RR: Alcoa 883677 22.5X8.25 Clean Buff Finish | -176 |
| | Aluminum | |
| | Code-rear Rim Qty 08 | 0 |
| | FF: Polish Wheels, Outer Surface, Sgl/Tdm Steer | 0 |
| | Polish outer surface of outer wheel. Without chrome wheel nuts. | |
| | RR: Polished Wheels, Outer Surface, Tandem Drive | 0 |
| | Polish outer surface of outer wheels (4). Without chrome wheel nuts. | |
| | Schrader 1126 Double Seating Extensions | 0 |
| | On Tire Valve Stems | |
| | FF: Dura-Bright Finish | 0 |
| | Outer Surface of Outer Wheel, Includes Wheel Guards, Requires Polished Option | |
| | RR: Dura-Bright Finish-Tandem Axle | 0 |
| | Outer Surface of Outer Wheel, Includes Wheel Guards, Requires Polished Option | |
| Fuel Tanks | | |
| | 26 in Aluminum 100 Gallon Fuel Tank LH U/C | 22 |
| | Includes steps for cab access. Paddle handle filler cap with threadless filler neck. Top draw fuel plumbing reduces chance of introducing air into the fuel system during low fuel level conditions due to the central placement of fuel pickup tube. Wire braid fuel lines increase durability & reduce potential for leaks. | |
| | Location LH U/C 100 Gallon | 0 |
| | Polish (1) Non-Slip Fuel Tank Step, U/C Tank Only | 0 |
| | Polish All Fuel / Hydraulic Tank Straps | 0 |
| | Does not apply to Rectangular Def Tank straps. | |
| | DEF Tank Mounted LH BOC | 0 |
| | Models 210, 220 and 320 mounted LH cab fender. | |
| | Paccar MX Engine Fuel Cooler | 15 |
| | Less Than Standard DEF To Fuel Ratio 2:1 | 0 |
| | Greater than minimum 1:1 | |
| | Polished Stainless Steel Cover For DEF Tank | 0 |
| | DEF Tank Small | 0 |
| | RH Tank None Furnished | -86 |
| Battery Box & Bumper | | |
| | Aluminum Space Saver Battery Box LH BOC | -20 |
| | Battery Access From Side | |

Unpublished options may require review/approval.

Dimensional and performance data for unpublished options may vary from that displayed in PROSPECTOR.

| | | | | |
|-----------------|------------------------|-----------------|-----------------|-----------|
| Printed: | 03/09/2018 10:02:18 AM | Complete | Model Number: | Model 365 |
| Effective Date: | Jan 1, 2018 | | Quote/DTPO/CO: | Q55854571 |
| Prepared by: | ID: Idomenico | | Version Number: | 36.10 |



| Description | Weight |
|--|--------|
| Rubber Battery Pad in Bottom Of (1) Battery Box Mat in box that holds batteries only | 4 |
| Polishing Battery/Tool Box(s), Aftertreatment Cab Entry complete | 0 |
| Aftertreatment RH U/C AlumNUM Non-Slip Cab Entry Step. DPF/SCR for diesel engines, catalyst for natural gas engines. On Models 579 specifying chassis fairings, the box will be aerodynamic. | 0 |
| Steel Bumper Swept Back Painted Black, With FEPTO (2) Tow pin holes and step plates on top of bumper | 79 |

Cab & Equipment

| | |
|--|-----|
| Alum Cab 115in BBC Fiberglass Hood SBFA Fenders w/polished crown, spring tilt assist. Proprietary anti-blow-down locking mechanism that keeps hood open during servicing & prevents unintentional closing. Hood latch each side secures hood to cowl. Proprietary all-alum cab is light weight & durable for long service life. One-piece roof reduces potential for leaks. Two-piece windshield for cost effective windshield replacement. Lap seam construction & aircraft fasteners has greater clamp load than rivets. Bulkhead style doors provide virtually water-tight, rattle-free performance. Extruded alum door frames for strength & durability. Full length, heavy-duty piano-type stainless steel door hinges & pins provide durability. View window in RH door for safety. Electric windshield wipers & washers w/intermittent wiper function. Grab handles mtd on cab LH & RH for cab access. Convex mirror over RH door & below each rear view mirror for improved visibility & safety. | 170 |
| Thermal Insulation Package in Cab Includes thick, closed-cell foam in floor, special mylar-faced foam in walls and roof structure. | 2 |
| No Sleeper Selected | 0 |
| Rubber Fender Lips 2 Inch Wide | 8 |
| Peterbilt UltraRide Driver Seat | 0 |
| Peterbilt UltraRide Passenger Seat | 0 |
| Drivers Armrest - RH Only Required in Model 587 with Evolution LX seats. Optional with Evolution ST and Rolltek Seats. | 2 |
| Black Seat Color ipo Standard Color | 0 |
| Air Ride Driver | 0 |
| High Back Driver | 0 |
| Vinyl Driver | 0 |
| Non-Air Ride Passenger | 0 |
| High Back Passenger | 0 |
| Vinyl Passenger | 0 |
| Adjustable Steering Column - Tilt/Telescope | 11 |

Unpublished options may require review/approval.
Dimensional and performance data for unpublished options may vary from that displayed in PROSPECTOR.

| | | | | |
|-----------------|------------------------|-----------------|-----------------|-----------|
| Printed: | 03/09/2018 10:02:18 AM | Complete | Model Number: | Model 365 |
| Effective Date: | Jan 1, 2018 | | Quote/DTPO/CO: | Q55854571 |
| Prepared by: | ID: Idomenico | | Version Number: | 36.10 |



| Description | Weight |
|---|--------|
| Steering Wheel with Peterbilt Logo Steering Wheel with embossed Peterbilt logo over horn button. | 0 |
| Prestige Interior - Arctic Gray Includes innovative charcoal A & B instrument panels and color-matched C & D instrument panels, monochromatic color-coordinated dash with glare-resistant, charcoal soft-touch upper, black bezel on gauges, cigar lighter and ashtray with power port, burlwood insert on contoured doorpads, LH and RH door mounted map pockets with built-in courtesy lights, 18 inch 4-spoke soft-touch steering wheel, soft-touch steering column cover, power lift passenger window, padded vinyl headliner and wall panels, extruded rubber floor covering, (2) inside sunvisors, (2) coat hooks, header-mounted domelight, driver and passenger dome/reading lights, footwell lighting, integrated "dead pedal", (5) inside entry grab handles, cup holder and map bin in dash. | 22 |
| Extended Rear Window ipo Std Window-Day Cab The extended rear window protrudes two inches more than the standard conventional rear cab window. Take this into consideration when determining your loadspace. | 0 |
| Day Cab Rear Window | 0 |
| One Piece Curved Windshield | 0 |
| Power Lift Windows - Both Doors For use with ProBill or Prestige Interior | 0 |
| Combo Fresh Air Heater/Air Conditioner With radiator mounted condenser, dedicated side window defrosters, Bi-Level Heater/Defroster Controls, 54,500 BTU/HR, and silicone heater hoses. | 0 |
| Peterbilt Comfort Control - Cab | 0 |
| Outside Sunvisor - Stainless Steel Not available with 2.1M high roof sleeper or furnished by owner sleeper. | 4 |
| Mirrors SSTL Each Side Heated and Motorized with Switch on Door. Right Click on option to See Picture in Product Portfolio. | 2 |
| (2) Convex 8 Inch SS Mirrors Center mounted under mirror bracket. If rear view mirrors are heated, the convex mirrors will be heated. Option includes dual door stops. | 0 |
| Polished Lower Mirror Bracket Covers | 0 |
| (2) Air Horns 24.5in Chrome - Round w/Horn Shield | 8 |
| Standard Speaker Package For Cab (2) Speakers | 4 |
| ConcertClass Without CD, Includes BT Phone and Audio, AM/FM, WB, USB and MP3. | 10 |
| CB Terminals/Wiring Mtd Under Header | 0 |
| CB Antenna Mounting, Inboard RH & LH | 0 |
| Mount CB Speaker LH Rear Corner Cab Headliner | 2 |

Unpublished options may require review/approval.
Dimensional and performance data for unpublished options may vary from that displayed in PROSPECTOR.

| | | | | |
|-----------------|------------------------|-----------------|-----------------|-----------|
| Printed: | 03/09/2018 10:02:18 AM | Complete | Model Number: | Model 365 |
| Effective Date: | Jan 1, 2018 | | Quote/DTPO/CO: | Q55854571 |
| Prepared by: | ID: Idomenico | | Version Number: | 36.10 |



| Description | Weight |
|---|--------|
| SmartLINQ Remote Diagnostics SmartLINQ is Peterbilt's proprietary remote diagnostics service which monitors the engine and aftertreatment for diagnostic codes providing real-time code analysis maximizing vehicle uptime and strengthening the fleets partnership with their dealer. SmartLINQ provides fault coverage for over 800 codes, a customizable email notification for 116 codes plus a web portal to manage your entire fleet included at no additional charge. SmartLINQ is compatible with any telematics system and doesn't require a specific fleet management system. For those whose customers utilize PeopleNet, the pre-wire with remote diagnostics will provide a more integrated solution utilizing the existing SmartLINQ modem. For those whose customers utilize other fleet services products, the existing pre-wire option for the other fleet service devices will continue to be available.. SmartLINQ is standard with MX-13 engines and available on the models 587,579,567,389,367 and 365. | 0 |
| Radio Antenna Mounted on LH Mirror Bracket | 0 |
| Plug-In Auto Reset Circuit Breaker in place of fuses in junction box. | 0 |
| Peterbilt Electric Windshield Wipers With Intermittent Feature. | 0 |
| Unibilt Cab Air Suspension Includes dual air bag suspension, leveling valve, and tracking rod. | 25 |
| Triangle Reflector Kit Shipped Loose | 13 |
| Fire Extinguisher; Cab Mounted Hazmat approved UL listed/rated ABC. | 8 |
| Backup Alarm (107dB) | 3 |
| Air Restriction Indicator Mounted on air cleaner,intake piping, or firewall. | 0 |
| Buzzer On Air Suspension Dump Valve Requires dash mounted dump valve (1922260) | 0 |
| Bright Bezel Gauges | 0 |
| Main Instrumentation Panel, Graphics Display Includes speedometer with tripodometer, tachometer with hourmeter and outside air temperature display, voltmeter, engine oil pressure, engine coolant temperature, fuel level, primary and secondary air pressure gauges. Includes standard warning light package: high water temperature, low oil pressure, and low air pressure warning lights w/audible alarms, high beam, turn signal, low fuel, parking brake, and ice warning indicators; seat belt reminder; rocker switches with long-life LED indicators; multi-function turn stalk with flash-to-pass feature (night mode flashes headlights and marker lights; day mode flashes headlights only), intermittent windshield wiper and headlamp beam control. Hydraulic braked trucks do not include air pressure gauges. | 0 |
| (1) Additional Dash Switch With Wiring Extra wire included at the switch. Availability subject to dash space. | 0 |
| Headlight Single Pod Mtd, Hella Vision Plus Integral turn signals | 0 |

Unpublished options may require review/approval.
 Dimensional and performance data for unpublished options may vary from that displayed in PROSPECTOR.

| | | | | |
|-----------------|------------------------|-----------------|-----------------|-----------|
| Printed: | 03/09/2018 10:02:18 AM | Complete | Model Number: | Model 365 |
| Effective Date: | Jan 1, 2018 | | Quote/DTPO/CO: | Q55854571 |
| Prepared by: | ID: Idomenico | | Version Number: | 36.10 |



| Description | Weight |
|--|--------|
| (5) Marker Lights, Aero LED Light Emitting Diodes | 0 |
| Switch And Wiring For F/O Beacon/Strobe 10ft coiled wire BOC/BOS at rear sill. | 2 |
| LED Stop/Turn/Tail/Backup Bracket mounted LH/RH EOF | 2 |
| Moveable EOF Xmbr For Mounting Taillights Square EOF with or without EOF xmbr. | 10 |
| (1) F/O Load Light, Switch & 10ft Wire Coil Under / in cab / sleeper | 2 |

Paint

| | |
|--|---|
| (1) Color Axalta Two Stage - Cab/Hood Base Coat/Clear Coat N85020 A - M2201EY EMERALD GREEN N85400 HOOD TOP M2201EY EMERALD GREEN N85500 CAB ROOF M2201EY EMERALD GREEN N85200 FRAME N0001EA BLACK N85700 BUMPER N0001EA BLACK N85300 FENDER M2201EY EMERALD GREEN | 0 |
| Axalta Two Stage Effect - Metallic/Pearl Cab/Hood & Sleeper Only | 0 |

Options Not Subject To Discount

| | |
|---|---|
| Peterbilt Class 8 Standard Coverage 1 year/100,000 Miles (160,000 km) | 0 |
| PACCAR MX Standard Coverage 2 yrs/250,000 mi (400,000 km)/6,250 hrs | 0 |

Miscellaneous

| | |
|---|---|
| Day Cab / Prestige Interior (DM) | 0 |
| 2017 EPA Emissions Engine Warranty Only | 0 |

| | |
|--|-----------|
| Total Adjusted Price (W/O Freight & Warranty & Surcharges) | \$221,859 |
| Freight Charge | \$2,225 |
| Options Not Subject to Discount | \$0 |
| Surcharges Not subject to Discount | \$0 |
| Total Weight | 17152 |

Prices and Specifications Subject to Change Without Notice.

Unpublished options may require review/approval.
Dimensional and performance data for unpublished options may vary from that displayed in PROSPECTOR.

| | | | | |
|-----------------|------------------------|-----------------|-----------------|-----------|
| Printed: | 03/09/2018 10:02:18 AM | Complete | Model Number: | Model 365 |
| Effective Date: | Jan 1, 2018 | | Quote/DTPO/CO: | Q55854571 |
| Prepared by: | ID: Idomenico | | Version Number: | 36.10 |



Hunter Truck Sales and Service H546
1328 Golden Slipper Road

Pocono Township
112 Township Dr

Bartonsville, Pennsylvania United States 18321
Phone: (570) 688-2400
Fax:
Email:

Tannersville, Pennsylvania United States 18372
Phone: (570) 888-4344
Fax:
Contact Email:
Prepared for: Donna Azure

Horizontal Dimensions

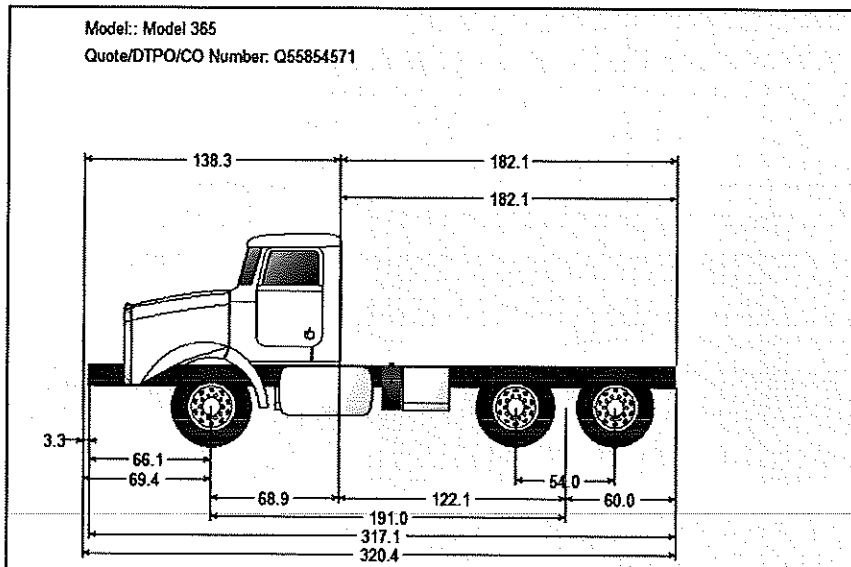

Unpublished options may require review/approval.

Dimensional and performance data for unpublished options may vary from that displayed in PROSPECTOR.

Printed: 03/09/2018 10:02:39 AM
Effective Date: Jan 1, 2018
Prepared by: ID: Idomenico

Complete

Model Number: Model 365
Quote/DTPO/CO: Q55854571
Version Number: 36.10



Hunter Truck Sales and Service H546
1328 Golden Slipper Road

Pocono Township
112 Township Dr

Bartonsville, Pennsylvania United States 18321
Phone: (570) 688-2400
Fax:
Email:

Tannersville, Pennsylvania United States 18372
Phone: (570) 888-4344
Fax:
Contact Email:
Prepared for: Donna Azure

Fuel Tanks

Summary
 Right Left

Location
Under Cab
Back Of Cab 1
Back Of Cab 2
Between Rails
ClearFrame
Def Tank

Type

Material

Diameter

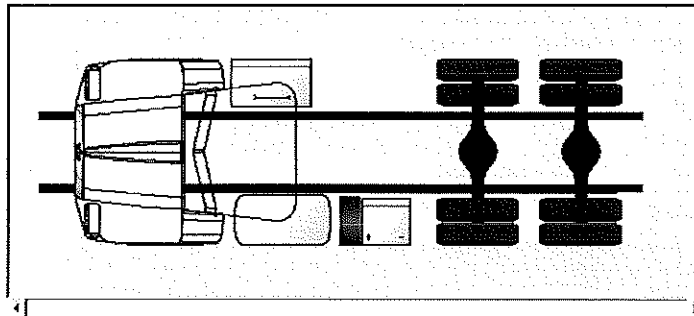

Top View Right Side Available Space: 60.70 in. Current Wheelbase Space: 191
 Side View Left Side Available Space: 8.60 in. Required Wheelbase Space: 183

| Position | Description | Price | Weight |
|-------------|---|-------|--------|
| RH Under | Aftertreatment RH U/C ALUMINUM Non-Slip Cab Entry | 0 | 0 |
| LH Under | 26 in ALUMINUM 100 Gallon Fuel Tank LH U/C | 660 | 22 |
| LH BOC1 | ALUMINUM Space Saver Battery Box LH BOC | 10 | -20 |
| LH Def Tank | DEF Tank Small | 0 | 0 |

Unpublished options may require review/approval.
Dimensional and performance data for unpublished options may vary from that displayed in PROSPECTOR.

Printed: 03/09/2018 10:03:00 AM **Complete** Model Number: Model 365
Effective Date: Jan 1, 2018 Quote/DTPO/CO: Q55854571
Prepared by: ID: Idomenico Version Number: 36.10



Hunter Truck Sales and Service H546
1328 Golden Slipper Road

Pocono Township
112 Township Dr

Bartonsville, Pennsylvania United States 18321
Phone: (570) 688-2400
Fax:
Email:

Tannersville, Pennsylvania United States 18372
Phone: (570) 888-4344
Fax:
Contact Email:
Prepared for: Donna Azure

Vehicle Weight Rating

Front Axle

| Component | Code | Description | Weight (lbs) |
|---------------------|---------|--|--------------|
| Axle | 1011360 | Dana Spicer D2000F 20,000 lb, 3.5 in. Drop | 20,000 |
| Springs | 1114030 | Taper Leaf Springs, Shocks 20,000 lb | 20,000 |
| Power Steering | 1233060 | Power Steering TRW TAS65 Dual | 20,000 |
| Hubs, Drums, Brakes | 1354840 | PHP10 Iron PreSet PLUS Hubs | 23,000 |
| Tires | 5033410 | FF: GY 20Ply 315/80R22.5 Endurance WHA | 20,400 |
| Wheels | 5220530 | FF: Alcoa 89U647 22.5X9.00 Clean Buff Finish | 20,000 |

Requested Front Axle Rating is 20,000

Front Axle Weight Rating is limited to 20,000 #

Rear Axle

| Component | Code | Description | Weight (lbs) |
|---------------------|---------|--|--------------|
| Axle | 1523340 | Dana Spicer D46-170 46,000 lb | 46,000 |
| Hubs, Drums, Brakes | 1616300 | PHP10 Iron PreSet PLUS Hubs | 72,000 |
| Parking Brakes | 1632650 | Long Stroke Parking Brakes, Drive Axle(s) | 70,000 |
| Suspension | 1821640 | Peterbilt Air Trac 46,000 lbs, 54in Axle Spacing | 46,000 |
| Tires | 5132310 | RR: GY 14ply 11R22.5 G182 RSD | 46,720 |
| Wheels | 5321740 | RR: Alcoa 883677 22.5X8.25 Clean Buff Finish | 59,200 |

Requested Rear Axle Rating is 46,000

The Rear Axle Weight Rating is limited to 46,000 #

Tire rating is based on tire psi. Tire psi is based on the max wheel psi. The tire psi cannot exceed the wheel max psi.

Unpublished options may require review/approval.
Dimensional and performance data for unpublished options may vary from that displayed in PROSPECTOR.

| | | | | |
|-----------------|------------------------|-----------------|-----------------|-----------|
| Printed: | 03/09/2018 10:03:11 AM | Complete | Model Number: | Model 365 |
| Effective Date: | Jan 1, 2018 | | Quote/DTPO/CO: | Q10354057 |
| Prepared by: | ID: Idomenico | | Version Number: | 36.10 |



Hunter Truck Sales and Service H546
1328 Golden Slipper Road

Pocono Township
112 Township Dr

Bartonsville, Pennsylvania United States 18321
Phone: (570) 688-2400
Fax:
Email:

Tannersville, Pennsylvania United States 18372
Phone: (570) 888-4344
Fax:
Contact Email:
Prepared for: Donna Azure

Weight Distribution

Weight Distribution

Actual performance of a specific unit can be affected by your operating conditions. The performance calculations should only be used as a guideline.

| Truck Spec | Auxiliary Payload |
|---|-------------------|
| Model: Model 365 Quote/DTPO/CO Number: Q10354057 | |
| | |

Recommended Payload Center of Gravity to achieve specified ground loads; measured from centerline of drive axle: 38 in. from the centerline of the drive axle(s)

| Weight (lbs) | Front | Rear | Total |
|---------------------|-------|-------|-------|
| Chassis | 9774 | 7378 | 17152 |
| Tools/Driver | 253 | 122 | 375 |
| Fuel & DEF | 489 | 333 | 822 |
| Max Payload | 9484 | 38167 | 47651 |
| Auxiliary Payload | 0 | 0 | 0 |
| Total | 20000 | 48000 | 68000 |
| Specify Ground Load | 20000 | 48000 | |

Unpublished options may require review/approval.
Dimensional and performance data for unpublished options may vary from that displayed in PROSPECTOR.

Printed: 03/09/2018 10:03:18 AM
Effective Date: Jan 1, 2018
Prepared by: ID: Idomenico

Complete

Model Number: Model 365
Quote/DTPO/CO: Q10354057
Version Number: 36.10



Hunter Truck Sales and Service H546
1328 Golden Slipper Road

Pocono Township
112 Township Dr

Bartonsville, Pennsylvania United States 18321
Phone: (570) 688-2400
Fax:
Email:

Tannersville, Pennsylvania United States 18372
Phone: (570) 888-4344
Fax:
Contact Email:
Prepared for: Donna Azure

Cruise Performance

Configuration: Model 365 / Full Truck GCW: 66000
Quote/DTPO/CO Number: Q55854571
Aerodynamic Aids: None

Engine: 2072610 PACCAR MX-11 400@1600 GV@2200 1450@900
Transmission: 4052420 Allison 4500 RDS-P Transmission, Gen 5
Rear Axle: 1523340 Dana Spicer D46-170 46,000 lb 4.30 Ratio
Rear Tire: 5132310 RR: GY 14ply 11R22.5 G182 RSD Revs/Mile: 496

Operating Conditions: 0.7% Rolling Resistance, Engine Fan: Off

Startability:

| Transmission Ratio | Maximum Starting Grade (%) |
|--------------------|----------------------------|
| 4.70 | 11.60 |
| 2.21 | 5.10 |

| Engine RPM: | 800 | 900 | 1000 | 1100 | 1200 | 1300 | 1400 | 1500 | 1600 | 1700 | 1800 | 1900 | 2100 | 2200 |
|---------------|------|------|------|------|------|------|------|------|------|------|------|------|------|------|
| Gross Torque: | 1152 | 1450 | 1449 | 1449 | 1449 | 1449 | 1449 | 1380 | 1320 | 1148 | 822 | 704 | | |
| Net Torque: | 1035 | 1316 | 1319 | 1321 | 1323 | 1325 | 1327 | 1264 | 1210 | 1051 | 748 | 640 | -14 | -13 |
| Net HP: | 158 | 226 | 251 | 277 | 302 | 328 | 354 | 361 | 368 | 340 | 257 | 231 | -6 | -6 |

| Gear Ratios: TRN:(1) 4.70 | RAX:(1) 4.30 | | | | | | | | | | | | | |
|---------------------------|--------------|------|------|------|------|------|------|------|------|------|------|------|------|------|
| Speed (MPH): | 4.8 | 5.4 | 6.0 | 6.6 | 7.2 | 7.8 | 8.4 | 9.0 | 9.6 | 10.2 | 10.8 | 11.4 | 12.6 | 13.2 |
| Grade (%): | 18.3 | 23.7 | 23.8 | 23.8 | 23.9 | 23.9 | 23.9 | 22.7 | 21.6 | 18.6 | 12.9 | 10.9 | -1.0 | -1.0 |

| Gear Ratios: TRN:(2) 2.21 | RAX:(1) 4.30 | | | | | | | | | | | | | |
|---------------------------|--------------|------|------|------|------|------|------|------|------|------|------|------|------|------|
| Speed (MPH): | 10.2 | 11.5 | 12.7 | 14.0 | 15.3 | 16.5 | 17.8 | 19.1 | 20.4 | 21.6 | 22.9 | 24.2 | 26.7 | 28.0 |
| Grade (%): | 8.1 | 10.5 | 10.5 | 10.5 | 10.5 | 10.5 | 10.5 | 10.0 | 9.5 | 8.1 | 5.5 | 4.5 | -1.1 | -1.1 |

| Gear Ratios: TRN:(3) 1.53 | RAX:(1) 4.30 | | | | | | | | | | | | | |
|---------------------------|--------------|------|------|------|------|------|------|------|------|------|------|------|------|------|
| Speed (MPH): | 14.7 | 16.5 | 18.4 | 20.2 | 22.1 | 23.9 | 25.7 | 27.6 | 29.4 | 31.3 | 33.1 | 34.9 | 38.6 | 40.5 |
| Grade (%): | 5.3 | 7.0 | 7.0 | 6.9 | 6.9 | 6.9 | 6.9 | 6.5 | 6.1 | 5.1 | 3.3 | 2.6 | -1.3 | -1.4 |

| Gear Ratios: TRN:(4) 1.00 | RAX:(1) 4.30 | | | | | | | | | | | | | |
|---------------------------|--------------|------|------|------|------|------|------|------|------|------|------|------|------|------|
| Speed (MPH): | 22.5 | 25.3 | 28.1 | 30.9 | 33.8 | 36.6 | 39.4 | 42.2 | 45.0 | 47.8 | 50.6 | 53.5 | 59.1 | 61.9 |
| Grade (%): | 3.1 | 4.1 | 4.1 | 4.0 | 4.0 | 3.9 | 3.9 | 3.5 | 3.2 | 2.5 | 1.3 | 0.8 | -2.0 | -2.1 |

Unpublished options may require review/approval.
Dimensional and performance data for unpublished options may vary from that displayed in PROSPECTOR.

| | | | | |
|-----------------|------------------------|-----------------|-----------------|-----------|
| Printed: | 03/09/2018 10:02:46 AM | Complete | Model Number: | Model 365 |
| Effective Date: | Jan 1, 2018 | | Quote/DTPO/CO: | Q55854571 |
| Prepared by: | ID: Idomenico | | Version Number: | 36.10 |



Gear Ratios: TRN:(5) 0.76 RAX:(1) 4.30
 Speed (MPH): 29.6 33.3 37.0 40.7 44.4 48.1 51.8 55.5 59.2 62.9 66.6 70.3 77.7 81.4
 Grade (%): 2.0 2.8 2.7 2.6 2.5 2.4 2.2 1.9 1.6 1.0 -0.1 -0.6 -2.9 -3.1

Gear Ratios: TRN:(6) 0.67 RAX:(1) 4.30
 Speed (MPH): 33.6 37.8 42.0 46.2 50.4 54.6 58.8 63.0 67.2 71.4 75.6 79.8 88.2 92.4
 Grade (%): 1.6 2.2 2.1 2.0 1.8 1.7 1.5 1.2 0.8 0.2 -0.8 -1.3 -3.5 -3.7

Engine RPM: 800 900 1000 1100 1200 1300 1400 1500 1600 1700 1800 1900 2100 2200
 Gross Torque: 1152 1450 1449 1449 1449 1449 1449 1380 1320 1148 822 704
 Net Torque: 1035 1316 1319 1321 1323 1325 1327 1264 1210 1051 748 640 -14 -13
 Net HP: 158 226 251 277 302 328 354 361 368 340 257 231 -6 -6

Unpublished options may require review/approval.
 Dimensional and performance data for unpublished options may vary from that displayed in PROSPECTOR.

| | | | | |
|-----------------|------------------------|-----------------|-----------------|-----------|
| Printed: | 03/09/2018 10:02:46 AM | Complete | Model Number: | Model 365 |
| Effective Date: | Jan 1, 2018 | | Quote/DTPO/CO: | Q55854571 |
| Prepared by: | ID: Idomenico | | Version Number: | 36.10 |

E. M. KUTZ, INC.
2456 Morgantown Road
Reading, PA 19607
610-775-3528/610-775-4848-Fax

Date March 28, 2018

Pocono Township
Cc: Hunter-Keystone Peterbilt

Sales Agent: Matt Lynott/Dale Smith

DESCRIPTION

Furnish and install the following per COSTARS 025-053

Chassis to arrive with front frame extension, Allison series 3000 transmission with PTO access, PTO switch and factory upfitter switches, 108" cab to center of tandem on Peterbilt chassis. Hydraulic system requires a minimum of 36" clear frame space behind cab for valve/tank components.

Body

Godwin/R&S AG Series Aluminum Dump Body
14' X 86" inside width X 48" side height X 54" Tailgate height
3/16" aluminum sides with vertical side braces only
Extruded aluminum top rails and bottom dirt shedder rails
Aluminum grip strut walkway between vertical side braces on each side
HD 1/4" 5454 aluminum floor material
3/16" cab shield, 18" length X 95" width, with built in wind deflector
1/4" aluminum tailgate with air operator - two way swing gate
5" aluminum I-beam longsills with rubber cushion strip
4" boxed aluminum extruded crossmembers on 12" centers
1/4" in. rear post material, with 3 oval light cut-outs each side
Steps on left front, outside and inside
Maihot CS130-5.5-3DA hoist

Hydraulics

CS24 PTO/P50 gear pump
Bosch Rexroth 5 spool valve in Stainless Steel enclosure
35 gallon aluminum tank with sight glass, filter assembly
CS 106 Hoist and Plow controller Dual joystick
Compu Spread model 520 spreader controller
All necessary hoses and fittings to complete circuit

Snow Plow

Gledhill Model 11HSBPR2 snow plow
11' x 42" high moldboard
4" X 20" D/A angle cylinders
Heavy duty mushroom shoes
Level lift
Blade guides
3/4 X 6" X 11' carbide cutting edge on plow

Plow Hitch

Gledhill Model FFLP front frame hitch
4 x 10" D/A lift cylinder
QCP connection for plow and hitch

Spreader

Swenson Model SAG stainless steel spreader
Gear box driven auger
Poly spinner
Dump body filler plates

Lights

Snow plow lights mounted on fenders
Four (4) oval LED amber lights mounted in cab shield
One (1) oval LED amber light mounted in each rear post
LED stop/tail/back-up lights in rear posts
LED spreader work light

Miscellaneous

24" aluminum tool box frame space permitting
Aero 575 automatic tarp system with double arms
Pintle plate with BP200 pintle
Welded/fabricated and plow hitch painted black
Exterior of body to be hand cleaned bare aluminum finish

Price Per Unit - \$70,489.00

Pricing reflects a cash or check discount. Credit card purchases will incur a 4% surcharge to be added to order total.

All prices quoted do not include applicable taxes unless otherwise noted.

Customer Approval By: _____
Name Title Date

Purchase Order Number: _____

F.O.B. E. M. Kutz, Inc.

Terms: Net due upon completion.

Delivery: Please allow 45 to 90 days to complete unit after equipment and chassis arrival.

Dump body components are currently at 12-14 weeks out

Paint - Due to the variety of colors currently being provided by chassis manufacturers, E. M. Kutz, Inc. can no longer guarantee a 100% match.

All claims are contingent upon strikes, accidents and other caused beyond our control, including similar contingencies to our shippers or vendors and relative to the subject matter hereof. Clerical errors are subject to correction.

Note: All chassis to arrive with sufficient material to mount and install fuel tank or tank filler necks. Any additional material or labor needed for this there will be an upcharge. Also any rerouting of exhaust needed to mount P.T.O. or pumps there will be an upcharge.

Price Valid for 30 Days From Above Date



Boucher & James, Inc.
CONSULTING ENGINEERS

AN EMPLOYEE OWNED COMPANY

INNOVATIVE ENGINEERING

Fountainville Professional Building
1456 Ferry Road, Building 500
Doylestown, PA 18901
215-345-9400
Fax 215-345-9401

2738 Rimrock Drive
Stroudsburg, PA 18360
570-629-0300
Fax 570-629-0306

559 Main Street, Suite 230
Bethlehem, PA 18018
610-419-9407
Fax 610-419-9408

www.bjengineers.com

April 3, 2018

Ms. DonnaASURE, Manager
Pocono Township
112 Township Drive
Tannersville, PA 18372

**SUBJECT: PAYMENT APPLICATION NO. 7
CONTROL VALVE REPLACEMENT PROJECT
POCONO TOWNSHIP
PROJECT NO. 1631006C**

Dear Ms.ASURE:

Enclosed is Payment Application No. 7, submitted by The Milnes Company for the pay period through April 2, 2018. The Application is for work performed in conjunction with the above referenced contract. Based on our review of this information we offer the following comments.

The work performed during this period of 3/1/18 to 4/2/18 included installation of valve systems, crane, electrical systems and control systems.

Based on our review of this request, we find the Contractor has completed work and materials having a value of Thirty-Eight Thousand, Seven Hundred and Eighty-Nine Dollars and Fifty Cents (\$38,789.50). With the deduction of the ten percent (10%) retainage totaling \$3,879.95, we recommend the Contractor receive payment of **Thirty-Four Thousand, Nine Hundred Ten Dollars and Fifty-Five Cents (\$34,910.55)**. This brings the amount paid to date to \$239,968.35 and the amount retained to date to \$ 26,663.15.

Sincerely,

Jon S. Tresslar, P.E., P.L.S.
Township Engineer

JST/MG/cg

Enclosure: The Milnes Company Payment Application No. 7

cc: Pat Briegel, Pocono Township

S:\2016\1631006C\Documents\Invoices\Milnes\Milnes.PayAppNo. 7.docx

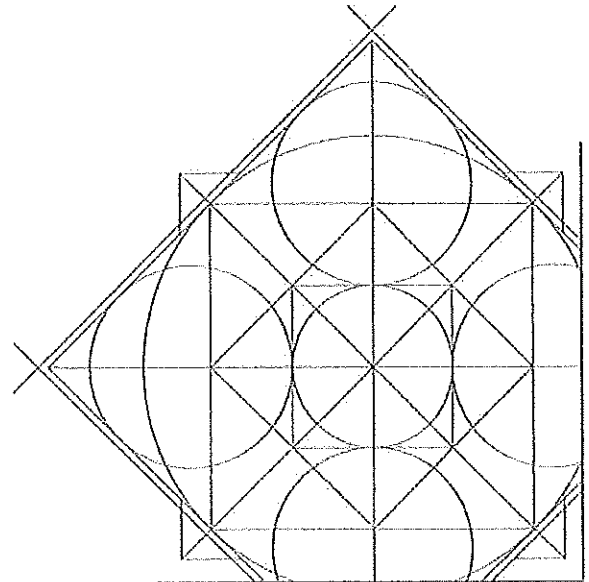

PAYMENT APPLICATION

TO: Pocono Township
112 Township Drive
Tannersville, PA 18372
Attn: Accounts Payable

FROM: The Milnes Co.
12 Frear Hill Road
Tunkhannock, PA 18657

FOR: Force Main Control Valve Replacement

PROJECT NAME AND LOCATION: Force Main Control Valve Replacement #1631006

ARCHITECT: Boucher & James, Inc.
2738 Rimrock Drive
Stroudsburg, PA 18360

APPLICATION # 7
PERIOD THRU: 04/02/2018
PROJECT #s: OWNER ARCHITECT CONTRACTOR

DATE OF CONTRACT: 10/19/2017

CONTRACTOR'S SUMMARY OF WORK

Application is made for payment as shown below. Continuation Page is attached.

| | |
|--|--------------|
| 1. CONTRACT AMOUNT | \$281,865.00 |
| 2. SUM OF ALL CHANGE ORDERS | \$43,369.33 |
| 3. CURRENT CONTRACT AMOUNT (Line 1 +/- 2) | \$325,234.33 |
| 4. TOTAL COMPLETED AND STORED (Column G on Continuation Page) | \$266,631.50 |
| 5. RETAINAGE: | |
| a. 10.00% of Completed Work (Columns D + E on Continuation Page) | \$26,663.15 |
| b. 10.00% of Material Stored (Column F on Continuation Page) | \$0.00 |
| Total Retainage (Line 5a + 5b or Column I on Continuation Page) | \$26,663.15 |
| 6. TOTAL COMPLETED AND STORED LESS RETAINAGE (Line 4 minus Line 5 Total) | \$239,968.35 |
| 7. LESS PREVIOUS PAYMENT APPLICATIONS | \$205,057.80 |
| 8. PAYMENT DUE | \$34,910.55 |
| 9. BALANCE TO COMPLETION (Line 3 minus Line 6) | \$85,255.98 |

| SUMMARY OF CHANGE ORDERS | ADDITIONS | DEDUCTIONS |
|---|--------------------|---------------|
| Total changes approved in previous months | \$43,369.33 | \$0.00 |
| Total approved this month | \$0.00 | \$0.00 |
| TOTALS | \$43,369.33 | \$0.00 |
| NET CHANGES | \$43,369.33 | |

Contractor's signature below is his assurance to Owner, concerning the payment herein applied for, that (1) the Work has been performed as required in the Contract Documents, (2) all sums previously paid to Contractor under the Contract have been used to pay Contractor's costs for labor, materials and other obligations under the Contract for Work previously paid for, and (3) Contractor is legally entitled to this payment.

CONTRACTOR: The Milnes Co.

By: *Karen Milnes-Seibert* Date: 4/2/18

State of: Pennsylvania
County of: Wyoming
Subscribed and sworn to before me this 2nd day of April 2018.

Notary Public: Karen Milnes-Seibert
My Commission Expires: May 11, 2021

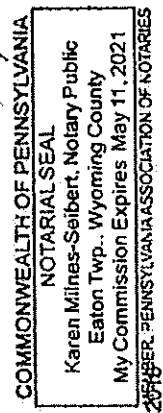

ARCHITECT'S CERTIFICATION

Architect's signature below is his assurance to Owner, concerning the payment herein applied for, that (1) Architect has inspected the Work represented by this Application, (2) such Work has been completed to the extent indicated in this Application, and the quality of workmanship and materials conforms with the Contract Documents, (3) this Application for Payment accurately states the amount of Work completed and payment due therefor, and (4) Architect knows of no reason why payment should not be made.

CERTIFIED AMOUNT: \$34,910.55

(If the certified amount is different from the payment due, you should attach an explanation. Initial all the figures that are changed to match the certified amount.)

ARCHITECT: *Engineer* Date: 4/3/18

By: _____

Neither this Application nor payment applied for herein is assignable or negotiable. Payment shall be made only to Contractor, and is without prejudice to any rights of Owner or Contractor under the Contract Documents or otherwise.

CONTINUATION PAGE

PROJECT: Force Main Control Valve Replacement #1631006
APPLICATION #: 7
DATE OF APPLICATION: 03/31/2018
PERIOD THRU: 04/02/2018
PROJECT #s:

Payment Application containing Contractor's signature is attached.

| A ITEM # | B WORK DESCRIPTION | C SCHEDULED AMOUNT | D COMPLETED WORK | | F STORED MATERIALS (NOT IN D OR E) | G TOTAL COMPLETED AND STORED (D + E + F) | H BALANCE TO COMPLETION (C-G) | I RETAINAGE (If Variable) |
|-------------|--------------------------------|-----------------------|-------------------------|--------------------|---------------------------------------|---|----------------------------------|------------------------------|
| | | | AMOUNT PREVIOUS PERIODS | AMOUNT THIS PERIOD | | | | |
| 1 | Mobilization | \$10,000.00 | \$10,000.00 | \$0.00 | \$0.00 | \$10,000.00 | \$0.00 | |
| 2 | Bond | \$5,637.00 | \$5,637.00 | \$0.00 | \$0.00 | \$5,637.00 | \$0.00 | |
| 3 | Remove Existing Control Valves | \$17,242.00 | \$8,621.00 | \$0.00 | \$0.00 | \$8,621.00 | \$8,621.00 | |
| 4 | Seal Leaks at Valve Pit 1 | \$846.00 | \$846.00 | \$0.00 | \$0.00 | \$846.00 | \$0.00 | |
| 5 | Install Power & Com Lines | \$10,030.00 | \$5,015.00 | \$2,006.00 | \$0.00 | \$7,021.00 | \$3,009.00 | |
| 6 | Install New Control Valves | \$37,190.00 | \$18,595.00 | \$0.00 | \$0.00 | \$18,595.00 | \$18,595.00 | |
| 7 | Install New Pressure Sensors | \$27,060.00 | \$13,530.00 | \$0.00 | \$0.00 | \$13,530.00 | \$13,530.00 | |
| 8 | New 1" Conduits to Panel | \$34,026.00 | \$34,026.00 | \$0.00 | \$0.00 | \$34,026.00 | \$0.00 | |
| 9 | Install New Vault Covers | \$28,082.00 | \$26,678.00 | \$0.00 | \$0.00 | \$26,678.00 | \$1,404.00 | |
| 10 | New Hoist Systems | \$82,673.00 | \$57,871.00 | \$24,802.00 | \$0.00 | \$82,673.00 | \$0.00 | |
| 11 | Valve Station 1 Electrical | \$26,419.00 | \$22,456.00 | \$1,321.00 | \$0.00 | \$23,777.00 | \$2,642.00 | |
| 12 | Install 70 Ft HDPE Air Line | \$2,660.00 | \$200.00 | \$1,795.00 | \$0.00 | \$1,995.00 | \$665.00 | |
| 13 | CO #1-Crane System Changes | \$14,230.00 | \$14,230.00 | \$0.00 | \$0.00 | \$14,230.00 | \$0.00 | |
| 14 | CO #2-Dismantling Joints | \$20,273.83 | \$10,137.00 | \$0.00 | \$0.00 | \$10,137.00 | \$10,136.83 | |
| 15 | CO #3-Relocate Iso Ring | \$8,865.50 | \$0.00 | \$8,865.50 | \$0.00 | \$8,865.50 | \$0.00 | |
| | TOTALS | \$325,234.33 | \$227,842.00 | \$38,789.50 | \$0.00 | \$266,631.50 | \$58,602.83 | |

LAW OFFICES of
BARNABA & MARCONI, LLP

MEMBERS NJ & PA BARS

MARIO L. BARNABA**
DENNIS M. MARCONI*

315 LOWELL AVENUE
TRINTON, NEW JERSEY 08619
Phone (609) 584-1444 ~ Fax (609) 584-1555

PHILADELPHIA OFFICE
19 SOUTH 21st STREET
PHILADELPHIA, PA 19103
(215) 386-4136

Charles C. Daley, Jr.*
Michael C. Corcoran

CHERRY HILL OFFICE
1913 GREENTREE ROAD
SUITE A
CHERRY HILL, NJ 08003
(856) 489-0776

April 5, 2018

* CERTIFIED AS A CIVIL TRIAL
ATTORNEY BY THE SUPREME
COURT OF NEW JERSEY

** CERTIFIED AS A WORKERS'
COMPENSATION ATTORNEY
BY THE SUPREME COURT OF
NEW JERSEY

Via Fax (570) 346-3452

Robert J. Munley, Esquire
Munley Law PC
227 Penn Avenue
Scranton, PA 18503

RE: Kevin Fontaine, Individually and as Parent and Natural Guardian of Zahair Fontaine, a minor v. Dreamland Amusements, Inc., Pocono Mountain Volunteer Fire Company et al. Monroe County CCP No. 4387-16

Dear Mr. Munley:

Please allow this letter to confirm that the above matter has settled for the amount of \$13,000. Enclosed please find a general release for your client's execution. At your earliest convenience, kindly provide me with the petition to approve the minor's compromise.

Should you have any questions, please feel free to contact my office.

Very truly yours,

MICHAEL C. CORCORAN

MCC/cl

Enclosure

cc: Leo V. Devito, Jr., Esquire, w/encl. (Via Fax - 610-865-0969)

FULL AND FINAL RELEASE OF ALL CLAIMS

KNOW ALL MEN BY THESE PRESENTS:

That Kevin Fontaine, Individually and as Parent and Natural Guardian of Zahair Fontaine, a minor ("Releasor"), for the sole consideration of \$13,000.00 (thirteen thousand dollars), lawful money to be paid collectively by or on behalf of Dreamland Amusements, Inc. and Pocono Mountain Volunteer Fire Company, has released and discharged, and by these presents does for himself and his assigns release and forever discharge Dreamland Amusements, Inc. and Pocono Mountain Volunteer Fire Company, and any of their past or present insurers, parent corporations, subsidiary corporations, divisions, partners, affiliated business entities, owners, stockholders, officers, directors, agents, employees, predecessors, or any of their respective successors, assigns, heirs or legal representatives, jointly and severally, of and from any and all liability, actions, causes of action, claims, suits, arbitration demands, debts, dues, accounts, bonds, covenants, contracts, agreements, judgments, demands and claims of whatsoever kind or nature, whether in law or in equity, whether or not heretofore, now, or hereafter known, as a direct or indirect result of any cause, matter or thing whatsoever which occurred or accrued at any time prior to the date of the execution of this Release, including, but not limited to any and all claims, actions or causes of action of whatsoever kind or nature relating to, arising from or connected with the carnival at the Pocono Mountain Volunteer Fire Company premises from July 20, 2014 through July 26, 2014., which is the subject of a lawsuit in the Court of Common Pleas/Monroe County, Docket no. - 4387-16, including all matters which were alleged and/or could have been alleged therein.

This release includes all claims or actions for contribution or indemnity now existing or that may arise on account of damages sustained or alleged to be sustained by third parties. This release also includes any and all claims for attorney fees, costs and/or expenses relating to, arising from or connected with the incident and/or civil action referenced in the preceding paragraph.

Releasor understands that Releasees, by reason of agreeing to this compromise payment, do not admit liability of any sort, and that Releasees have made no agreement or promise to do or omit to do any act or thing not herein set forth, and further understand that this Release is made as a compromise to avoid expense and to terminate all controversy and/or claims for injuries or damages against Releasees and any affiliated or related persons or entities, both known and unknown, including further developments thereof, in any way growing out of or connected with the incident referenced hereinabove. It is specifically agreed that this Release shall be a complete bar to all claims or suits against Releasees for injuries or damages of whatsoever nature resulting or to result from the incident referenced above. Releasor also agrees to hold harmless, defend and indemnify Releasees for any claim brought by Releasors' public adjuster and/or any other person or entity arising out of this settlement or the proceeds thereof.

In consideration of the settlement proceeds to be paid to me, I agree to pay and fully satisfy, from the settlement proceeds and before the distribution of any of those proceeds to me, any and all liens, whether public or private, for any medical, income or other benefits received by the Releasor, or paid to any third party for the benefit of the Releasors, or paid by any third

party for the benefit of the Releasors arising from the accident that forms the basis of this matter, including, but not limited to, liens asserted by any healthcare provider, hospital, insurer or attorney for medical expenses, hospital expenses, lost earnings, payments, attorney liens, subrogation claims or liens, any Workers' Compensation liens, or other statutorily mandated liens such as any Child Support lien imposed by law, and any future lien by any person or entity as outlined above that has not been previously made known to the parties herein as a result of the accident/occurrence in issue.

I further agree to indemnify, defend and hold harmless the Releasees, as identified in this Release, and their representatives, attorneys and insurance carrier, from any liability for the non-payment of any liens or obligations up to the amount of the settlement.

Releasors for the consideration set forth in this Release Agreement, further agrees to satisfy any and all liens or claims against the proceeds of this Agreement, specifically including, but not limited to, any lien, claim or conditional payment reimbursement demand asserted by or on behalf of Medicare or any entity claiming any right of reimbursement under the Medicare Secondary Payer Act. Releasors further agree to hold harmless, indemnify and defend Releasees and Releasees' counsel of record from any claims arising from the failure of Releasors and/or Releasors' counsel of record to satisfy any such liens, claims, and/or Medicare conditional payment reimbursement demands. These obligations include Releasors' payment and/or reimbursement of any and all reasonable attorney's fees and expenses incurred by Releasees and/or Releasees' counsel of record in connection with the with the failure of Releasors and/or Releasors' counsel of record to satisfy any such liens, claims, and/or Medicare conditional payment reimbursement demands.

Releasors also agree to hold harmless, indemnify, and defend Releasees and Releasees' counsel of record with respect to any and all other claims that may be presented by Releasors, Medicare, and/or any other party acting on Releasors' or Medicare's behalf, including, but not limited to, administrative or civil fines, penalties, and interest, as well as any damages that arise out of, result from, and/or occur as a consequence of any adverse administrative or legal actions, up to and including the loss of Releasors' future Medicare benefits and/or Medicare eligibility. These obligations include Releasors' payment and/or reimbursement of any and all reasonable attorney's fees and expenses incurred by Releasees and/or Releasees' counsel of record in connection with the failure of Releasors and/or Releasors' counsel of record to perform these obligations.

The parties to this Release Agreement acknowledge that Releasors may choose to obtain a Medicare Set Aside Arrangement ("MSA") when Releasors' liability claims have been resolved. The parties further acknowledge that Releasees and/or Releasees' counsel of record have not provided any advice, legal or otherwise, as to whether such MSA is required, needed or warranted, or how it should be structured or funded. Releasors undertake and acknowledge complete responsibility for the implementation of any such MSA. Releasors further agrees to hold harmless, indemnify, and defend Releasees and/or Releasees' counsel of record from any claims or liabilities arising out of or in any way connected with any such MSA, including any and all reasonable attorney's fees and expenses incurred by Releasees and/or Releasees' counsel of record in connections therewith.

The funding of this settlement agreement by the Releasees is made in reliance on Releasors' agreement to fulfill the obligations set forth in paragraph 1, 2 and 3 above. The provisions of paragraph 1, 2, and 3 above shall survive the execution of this Release Agreement and shall be enforceable at any time in the future, and Releasors specifically agree and acknowledge that any potential Statute of Limitations defense is waived forever with regard to the above-stated duty to hold harmless, indemnify and defend and shall be binding upon Releasors' heirs, successors and assigns.

Releasor represents and warrants that any and all bills and costs resulting from or arising out of Plaintiff's alleged injuries from the above-referenced incident, including but not limited to any and all claims and/or liens by any third parties seeking reimbursement of payments made for those medical bills and costs for which Releasor sought reimbursement in the above-referenced civil action, are Releasor's sole responsibility to pay. Releasor agrees to assume responsibility for any and all past and future bills, costs, and expenses incurred by Releasor in her relation to all injuries which were or could have alleged in the above-referenced civil action, including but not limited to all Medicare conditional payments, subrogation claims, liens, or other rights to payment that have been or may be asserted by any health care provider, insurer, governmental entity, or other person or entity. Releasor expressly agrees to defend, indemnify, and hold harmless Releasees should any third parties pursue Releasees for reimbursement of payments made for those medical bills and costs for which Releasor sought reimbursement, or could have sought reimbursement, in connection with Releasor's claim for personal injuries arising from the above-referenced incident. Releasor further expressly agrees to indemnify, defend, and hold harmless Releasees with respect to any attorneys' fees and other costs and expenses incurred by any person, entity, or governmental agency to recover the amount of any payments made for such medical bills and costs. Releasor and Releasor's counsel further represent and warrant that Plaintiff is not a Medicare beneficiary as of the date of this release, and that no conditional payments have been made by Medicare on Plaintiff's behalf.

It is understood and agreed by Releasor that Releasor alone shall be responsible for any payment due and owing for federal, state and/or local tax, if any, which may be due and owing by or on behalf of Releasor as a result of Releasor's receipt of the monetary consideration being paid to them in connection with this Full and Final Release. Releasor expressly agrees to defend, indemnify and hold harmless Releasees should any taxing authority pursue Releasees for an alleged failure to withhold applicable taxes in association with the monetary consideration being paid to Releasor as referenced in this Full and Final Release.

It is understood and agreed that this is a compromise settlement of a disputed claim, liability for which is expressly denied by Releasees, and that the existence of this Release or any of its provisions, or any negotiations or proceedings connected therewith, shall not be offered or received in evidence in any action or proceeding as an admission or concession of liability or wrongdoing of any nature.

It is understood and agreed by and between the parties that this is a complete and full release, and that there are no written or oral understandings or agreements, directly or indirectly connected with this release and settlement agreement, that are not incorporated herein. It is

further understood and agreed by and between the parties that any and all provisions contained herein shall be construed in a neutral manner and pursuant to the law of the Commonwealth of Pennsylvania.

Releasor represents and warrants that she has carefully and thoroughly reviewed this Full and Final Release with the counsel and assistance of her attorney; that she understands the terms and conditions set forth herein; and that she has knowingly and voluntarily executed this Full and Final Release, with intent to be legally bound thereby.

THE UNDERSIGNED HAVE READ OR HAD EXPLAINED TO US THE FOREGOING SETTLEMENT AGREEMENT AND RELEASE, FULLY UNDERSTAND IT AND AGREE TO ABIDE BY ITS TERMS.

Witnessed or Attested by:

_____(Seal)
Kevin Fontaine, Individually

_____(Seal)
Kevin Fontaine, as Parent and Natural
Guardian of Zahair Fontaine, a minor

STATE OF PENNSYLVANIA)
) ss.:
COUNTY OF)

I CERTIFY that on April _____, 2018, Kevin Fontaine, Individually and as Parent and Natural Guardian of Zahair Fontaine, a minor, personally came before me and acknowledged under oath, to my satisfaction, that this person (or if more than one, each person):

- (a) is named in and personally signed this document; and
- (b) signed, sealed and delivered this document as his or her act and deed.

_____ (Seal)

Prepared by:

MICHAEL C. COCORAN, ESQUIRE
Attorney at Law of Pennsylvania